

1 GENERAL INFORMATION

CONTENTS

1-1	GENERAL INFORMATION	3
	MODEL IDENTIFICATION	3
	FRAME NUMBER	3
	ENGINE NUMBER	3
	FUEL AND OIL RECOMMENDATIONS	3
	FUEL	3
	ENGINE OIL	3
	BREAK-IN PROCEDURE	3
1-2	GENERAL INFORMATION	4
	SPECIFICATIONS (7150)	4
1-3	GENERAL INFORMATION	5
	SPECIFICATIONS (6150)	5
1-4	GENERAL INFORMATION	Error! Bookmark not defined.
	LOCATION OF PARTS:	Error! Bookmark not defined.

1-1 GENERAL INFORMATION

MODEL IDENTIFICATION

FRAME NUMBER

The frame number or VIN can be found on a plate, which is located on the crossbar, behind the seats for fun karts, or under the dump bed on 200 Series vehicles.

ENGINE NUMBER

The engine number is located on the lower front left side of the engine cases.

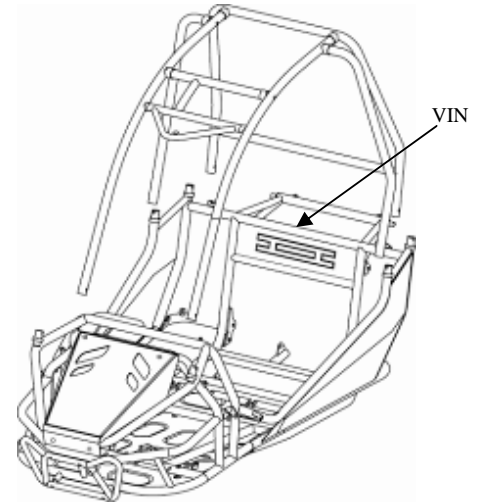

FUEL AND OIL RECOMMENDATIONS

Be sure to use the specified fuel and oil.

FUEL

Only use midgrade unleaded gasoline (89 – 93 octane).

ENGINE OIL

A high-grade 10W-40 motor oil should be used.

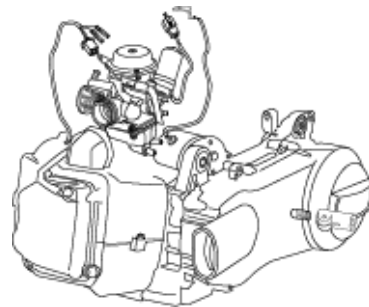

BREAK-IN PROCEDURE

For the first 2 hours of riding, do not exceed 2/3 throttle.

Vary engine speed for the first 5 hours.

Never hold engine at full throttle for long periods of time.

1-2 GENERAL INFORMATION

SPECIFICATIONS (7150)

DIMENSIONS

Overall length -----	2160mm (85.0 inch)
Overall width -----	1406mm (55.4inch)
Overall height -----	1458mm (57.4inch)
Wheelbase-----	1500mm (59.0inch)
Track Width – Front / Rear-----	1160mm (47.7inch) / 1000mm (39.4inch)
Ground Clearance-----	170mm (6.7inch)

ENGINE

Type-----	single cylinder oil & cooled 4 stroke
Engine capacity -----	150cc
Bore x stroke -----	57.4 x 57.8
Corrected Compression Ratio-----	9.2: 1
Carburetor-----	KF,CB24J
Output Power / Torque [N.m(r/min)-1]-----	9,9 hp @ 7500rpm / 13ft-lbs @ 5500rpm
Starting -----	keyed Electric
Ignition -----	CDI
Lubrication-----	Cooled Force & Splash SAE-10W/40
Transmission-----	CVT Automatic with Neutral and Reverse
Spark Plug / Gap-----	C7HSA (NGK) / 0.6 – 0.7mm
Fuel Type-----	USE ONLY Mid-Grade Unleaded (89 - 93 Octane)

CAPACITIES

Maximum Load (Driver, Passenger, & Gear) -----	400lbs
Climbing Angle -----	20-25°
Fuel tank -----	2.64 Gal
Engine Oil-----	6150 (without oil cooler) – 30oz / 7150 (with oil cooler) – 36.7oz
Battery-----	12V 9Ah
Head Light -----	12V 35W
Tail Light-----	12V 21W / 5W
Top Speed (20mph Speed Reduction Kit Available) -----	35 – 39mph

CHASSIS

Brakes (Front and Rear) -----	Hydraulic disc/left foot control
Tires – Front / Rear -----	19 x 7.0-8 @ 15psi / 21 x 10-10 @ 15psi
Suspension-Front -----	Dual A-arm with 1.8” (45mm) of travel
Suspension-Rear -----	Spring over shock with 2.4”(60mm) of travel

WEIGHT

Dry Weight-----	237Kg / 522lbs
-----------------	----------------

WARRANTY

Components -----	30 days
Frame -----	90 days
Engine -----	1 year

* The specifications are subject to change without notice.

1-3 GENERAL INFORMATION

SPECIFICATIONS (6150)

DIMENSIONS

Overall length -----	2311mm (91.0inch)
Overall width -----	1200mm (47.3inch)
Overall height -----	1406mm (55.4inch)
Wheelbase-----	1500mm (59.0inch)
Track – Front / Rear -----	1040mm (41.0inch) / 920mm (36.3inch)
Ground Clearance-----	170mm (6.7inch)

ENGINE

Type-----	single cylinder oil & cooled 4 stroke
Engine capacity -----	150cc
Bore x stroke -----	57.4 x 57.8
Corrected Compression Ratio-----	9.2: 1
Carburetor-----	KF,CB24J
Output Power / Torque [N.m(r/min)-1]-----	9,9 hp @ 7500rpm / 13ft-lbs @ 5500rpm
Starting -----	keyed Electric
Ignition -----	CDI
Lubrication-----	Force & Splash SAE-10W/40
Transmission-----	CVT Automatic with Neutral and Reverse
Final Drive Chain-----	KMC #50 – 5/8” Pitch
Spark Plug / Gap-----	C7HSA (NGK) / 0.6 – 0.7mm
Fuel Type-----	USE ONLY Mid-Grade Unleaded (89 - 93 Octane)

CAPACITIES

Maximum Load (Driver, Passenger, & Gear) -----	400lbs
Climbing Angle -----	20-25°
Fuel tank -----	2.64 Gal
Engine Oil-----	30oz
Battery-----	12V 9Ah
Fuse -----	15A
Top Speed (20mph Speed Reduction Kit Available) -----	35 – 39mph

CHASSIS

Rear Brake -----	Hydraulic disc/left foot control
Tires – Front / Rear -----	17 x 7.0-8 @ 15psi / 18 x 9.5-8 @ 15psi
Suspension-Front -----	Dual A-arm with 1.8” (45mm) of travel
Suspension-Rear -----	Spring over shock with 2.4”(60mm) of travel

WEIGHT

Dry Weight-----	198Kg (436lbs)
-----------------	----------------

WARRANTY

Components -----	30 days
Frame -----	90 days
Engine -----	1 year

* The specifications are subject to change without notice.

1-4 GENERAL INFORMATION

SPECIFICATIONS (200 SERIES)

DIMENSIONS

Overall length -----	2388mm (94.0 inch)
Overall width -----	1245mm (49.0inch)
Overall height -----	1784mm (70.25 inch)
Wheelbase-----	1588mm (62.5 inch)
Track Width – Front / Rear-----	1049mm (41.3 inch) / 1000mm (39.4 inch)
Ground Clearance-----	170mm (6.7 inch)

ENGINE

Type-----	Single cylinder oil & cooled 4 stroke
Engine displacement -----	150cc
Bore x stroke -----	57.4 x 57.8
Corrected Compression Ratio-----	9.2: 1
Carburetor-----	DENI,JB24J
Output Power / Torque [N.m(r/min)-1]-----	9.0 hp @ 7500rpm / 13ft-lbs @ 5500rpm
Starting -----	Keyed Electric
Ignition -----	CDI
Lubrication-----	Cooled Force & Splash SAE-10W/40
Transmission-----	CVT Automatic with Neutral and Reverse
Spark Plug / Gap-----	C7HSA (NGK) / 0.6 – 0.7mm
Fuel Type-----	ONLY USE Mid-Grade Unleaded (89 - 93 Octane)

CAPACITIES

Maximum Load (Driver, Passenger, & Gear) -----	340Kg / 750lbs
Maximum Bed Load-----	114 Kg / 250lbs
Bed Capacity-----	0.127 cu m / 4.5 cuft
Under-Seat Storage Capacity-----	0.09 cu m / 3.25 cuft
Maximum Towing Capacity (Rolling Load)-----	227 Kg / 500lbs
Climbing Angle-----	15-20°
Fuel tank -----	10 L / 2.64 Gal
Engine Oil-----	-(with oil cooler) – 36.7oz
Battery -----	12V 9Ah
Head Light / Tail Light-----	Twin 12V 25W / 12V 10W/5W
Cargo Light-----	12V 25W
Top Speed (Speed Limited) -----	45 – 48 kph / 28 – 30mph

CHASSIS

Brakes (Front and Rear) -----	Hydraulic disc
Tires – Front / Rear -----	20 x 8.0-8 @ 15psi / 22 x 11-10 @ 15psi
Suspension-Front -----	Dual A-arm with 1.8” (45mm) of travel
Suspension-Rear -----	Spring over shock with 2.0”(60mm) of travel

WEIGHT

Dry Weight-----	314Kg / 690lbs
-----------------	----------------

* The specifications are subject to change without notice.

2 MAINTENANCE AND TUNE-UP PROCEDURES

CONTENTS

2-1	MAINTENANCE AND TUNE-UP PROCEDURES	8
	PERIODICAL CHECKS AND SERVICES	8
2-2	PERIODIC MAINTENANCE AND TUNE-UP PROCEDURES	9
	MAINTENANCE AND TUNE-UP PROCEDUREs	9
	IDLE SPEED ADJUSTMENT	9
	SPARK PLUG	9
	TIRE PRESSURE/WEAR	9
	BRAKE FLUID AND PERFORMANCE	9
2-3	PERIODIC MAINTENANCE AND TUNE-UP PROCEDURES	10
	AIR CLEANER	10
	PAPER FILTER MAINTENANCE	10
	FOAM FILTER MAINTENANCE	10
	CHASSIS NUTS AND BOLTS	10
2-4	PERIODIC MAINTENANCE AND TUNE-UP PROCEDURES	11
	TIGHTENING TORQUE CHART	11
	FUEL SWITCH (PETCOCK)	11
	FUEL FILTER	11
	FINAL GEAR OIL	11
2-5	PERIODIC MAINTENANCE AND TUNE-UP PROCEDURES	12
	ENGINE OIL	12
2-6	PERIODIC MAINTENANCE AND TUNE-UP PROCEDURES	13
	CHASSIS	13
	CARBURETOR	13
	VALVE CLEARANCE	13
	SHIFTER ADJUSTMENT	13
	CHAIN TENSION	13
	BATTERY	13

2-1 MAINTENANCE AND TUNE-UP PROCEDURES

PERIODICAL CHECKS AND SERVICES

The maintenance intervals in the following table are based upon average riding conditions. Riding in unusually dusty areas require more frequent servicing.

Interval	Initial service (first week)	Monthly	Quarterly	Yearly
IDLE SPEED ADJUSTMENT (p. 9)	I	I		
SPARK PLUG (p. 9)			C, A	I
TIRE PRESSURE/WEAR (p. 9)	I	I		
BRAKE FLUID AND PERFORMANCE (p. 9)	I	I		
AIR CLEANER (p. 10)		C	C	I
CHASSIS NUTS AND BOLTS (p. 11)	I	I		
FUEL SWITCH (PETCOCK)/ FUEL FILTER (p. 11)		I		C, I, R
FINAL GEAR OIL (p. 11)		I	R	
ENGINE OIL (p. 12)	R (5hr)	R (10 hr)		
CHASSIS (p. 13)		C, I	L	
CARBURETOR (p. 13)	I	A		C
VALVE CLEARANCE (p. 13)			A	
SHIFTER ADJUSTMENT (p. 13)				
CHAIN TENSION (p. 13)	I	I	C, A, L	
BATTERY (p. 13)	I		I	

A: adjust **C:** clean **I:** inspect, clean or replace if necessary. **L:** lubricate **R:** replace

2-2 PERIODIC MAINTENANCE AND TUNE-UP PROCEDURES

MAINTENANCE AND TUNE-UP PROCEDURES

This section describes the servicing procedures for each item in the Periodic Maintenance requirements.

IDLE SPEED ADJUSTMENT

Over time, engine idle speed may become too high or too low and hinder proper vehicle performance. If this happens, proper adjustments must be made to the components that affect the idle speed. The three main components that directly affect idle speed are the Throttle Pedal, Throttle Cable, and Carburetor. Indirectly, the Fuel Line and Fuel Cock may also affect idle speed. Set the idle speed to 1500 +/- 150rpm. Ensure the belt is not engaging at idle.

SPARK PLUG

Clean up the carbon around the spark plug to prevent it from dropping into the cylinder when removing the spark plug.

Remove the spark plug

In general, this process should be performed after the engine has cooled.
If the spark plug is too tight to remove, spray penetrating oil on the spark plug washer and the threads, rotate the spark plug after soaking.

Clean up the filth and carbon accumulation on the spark plug with a steel brush or a blade.

Inspect the spark plug gap, in general it should be about 0.6 ~ 0.7mm.

When the carbon accumulation and wear of the spark plug are advanced, replace the spark plug. Replace with a spark plug of the same specification.

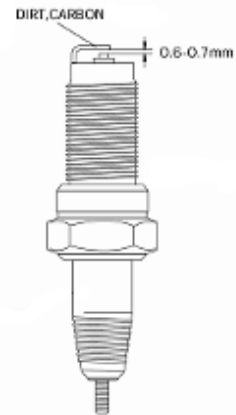

TIRE PRESSURE/WEAR

Check the tire pressure every time the vehicle is ridden. The tire pressure is very important for the stability of the ride.

For proper tire pressure ratings, see sections 1-2 and 1-3.

BRAKE FLUID AND PERFORMANCE

Always check that there is plenty of brake fluid in the brake fluid reservoir.

Ensure brake fluid looks clean and brake hoses are in good condition

Check that the front (7150 only) and rear brake pads are in good condition.

Check the brake rotors for abnormal wear.



2-3 PERIODIC MAINTENANCE AND TUNE-UP PROCEDURES

AIR CLEANER

Clean quarterly or more if the vehicle is driven in dusty conditions.

If the air cleaner is clogged with dust, performance will be severely decreased and if left unserviced, engine damage can occur. Check and clean in the following manner.

PAPER FILTER MAINTENANCE

Remove the air cleaner from its housing.

Tap filter on an object knocking dust from filter.

Replace the element if it is wrinkled torn.

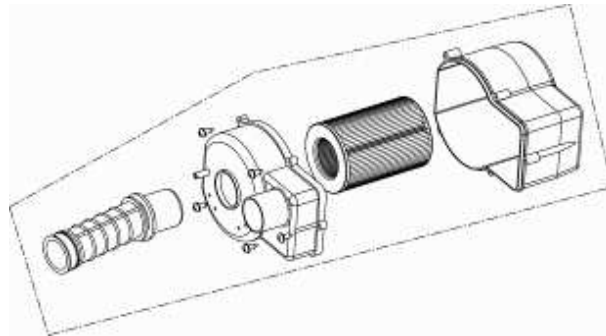

FOAM FILTER MAINTENANCE

Remove foam filter from steel cage

Wash in non-flammable cleaning solvent

Submerge in oil and squeeze to remove excess oil

Install the element back into the air box.

CAUTION!

Before and during cleaning, inspect the element for tears. A torn element must be replaced.

Make sure the element is seated properly and no foreign material can pass by it.

CHASSIS NUTS AND BOLTS

Inspect first week and every month thereafter

Always pay attention to the vehicles nuts and bolts. Some loosening after use is normal and should not be left unchecked for an extended period of time.

2-4 PERIODIC MAINTENANCE AND TUNE-UP PROCEDURES

TIGHTENING TORQUE CHART

Bolt Diameter (mm)	Conventional marked bolt			8.8 marked bolt		
	N.m	Kg.m	Ib-ft	N.m	Kg.m	Ib-ft
4	1 ~2	0.1 ~0.2	0.7 ~1.5	1.5 ~3	0.15 ~0.3	1.0 ~2.0
5	1 ~4	0.2 ~0.4	1.5 ~3.0	3 ~6	0.3 ~0.6	2.0 ~4.5
6	4 ~7	0.4 ~0.7	3.0 ~5.0	8 ~12	0.8~1.2	6.0 ~8.5
8	10 ~16	1.0 ~1.6	7.0 ~11.5	18 ~28	1.8 ~2.8	13.0 ~20.0
10	22 ~35	2.2 ~3.5	16.0~25.5	40 ~60	4.0 ~6.0	29.0 ~43.5
12	35 ~50	3.5 ~5.5	25.5 ~40	70 ~100	7.0 ~10.0	50.5 ~72.5
14	50 ~80	5.0 ~8.0	36.5 ~58	110 ~160	11.0 ~16.0	79.5 ~115.5
16	80 ~130	8.0 ~13.0	58 ~94	170 ~250	17.0 ~25.	123.0 ~181.0
18	130 ~190	13.0~19.0	94 ~137.5	200 ~280	20 ~28.0	144.5 ~202.5

FUEL SWITCH (PETCOCK)

This vehicle is equipped with an automatic fuel petcock. There is no need to turn off the fuel, since this happens when the engine is not running.

Check for any leaks or seeping fuel.

Replace the petcock if there are any leaks found.

FUEL FILTER

Ensure the fuel filter is in an upright position, so that no air can get pulled into the carburetor. Also, visually inspect the filter for debris, damage, or leaking. Replace filter at specified interval.

FINAL GEAR OIL

Inspect monthly and change quarterly.

To check level, remove level screw on the right rear of engine case.



2-5 PERIODIC MAINTENANCE AND TUNE-UP PROCEDURES

To drain oil, remove the drain plug at the rear bottom of the engine case. It is recommended to warm the engine for 10 minutes or more before draining final drive oil.

NOTE:

80/90 wt. Gear oil is recommended in the final drive case. However, in extreme cold weather conditions, you may experience the vehicle to be hard to push. In this case, lighter viscosity oil may be used, such as 75 wt., or equivalent motorcycle transmission fluid.

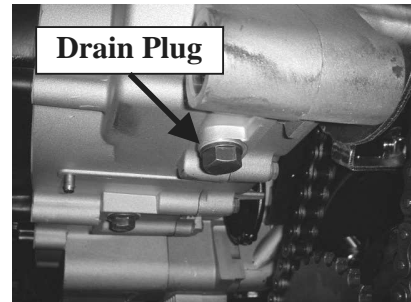

Final drive capacity	750ml 80/90wt
----------------------	---------------

ENGINE OIL

Inspect before riding, every time. Replace monthly.

Remove the drain plug from the left side bottom of the engine. Drain into oil pan for disposal. If the vehicle is equipped with an oil filter, remove the filter and discard any existing oil in an approved container

Replace oil drain plug.

Remove the large cap on the right bottom of the engine and remove the screen.

Wash the screen with cleaning solvent and refit, making sure the O-ring is still in good condition. Re-install the screen and cap.

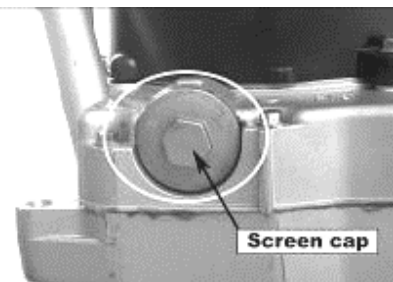

Refill the engine with 30oz of 10W-40 engine oil.

If your vehicle is equipped with an oil filter, add additional new oil to the filter, until the oil is 2mm or so from the top of the filter, then install the filter. (See Section 3-46, OIL SYSTEM INSPECTION AND SERVICING (W/ OIL FILTER))

Start and run engine for 5 minutes, ensuring there are no oil leaks present.

Allow time for oil to return to oil pan, then check oil level on the filler cap stick to assure proper level.

The cap needs to be screwed in to check.



2-6 PERIODIC MAINTENANCE AND TUNE-UP PROCEDURES

CHASSIS

Grease chassis bushings and bearings with grease quarterly to assure smooth operation and extended life of the bushings and the components.

If used in extreme wet and muddy conditions or dusty conditions, it is recommended more often.

CARBURETOR

Refer to Section 3-21, CV CARBURETOR.

VALVE CLEARANCE

Refer to Section 3-7, VALVE CLEARANCE ADJUSTMENT.

SHIFTER ADJUSTMENT

Your unit may require an occasional adjustment in the shift cables due to typical stretch found during normal operation of the vehicle. To make shift adjustments refer to the following procedure:

- Push the shift lever to the “D” position
- Check the restriction control disc found just behind the oil level dipstick to ensure that it has rotated forward all the way (looking for any slack in control cable #1)
- Loosen adjustment nuts #1 and #2, pulling the housing to draw the cable tight. Re-tighten the nuts when the cable is properly tensioned.
- Shift the lever to the “R” position and check the control disc to ensure that it has rotated full towards the rear of the vehicle.
- Loosen adjustment nuts #3 and #4, pulling the cable housing to draw the #2 control cable tight.
- Re-tighten nuts #3 and #4 when the cable is properly tensioned.

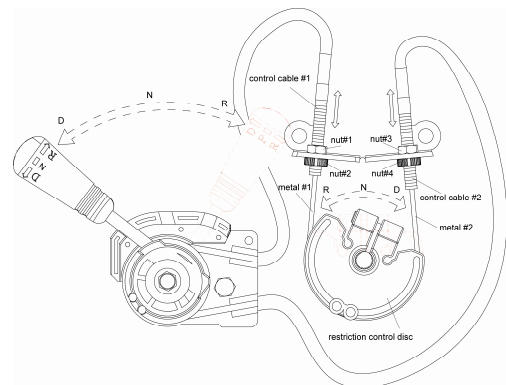

CHAIN TENSION

Refer to Section 5-4, CHAIN ADJUSTMENT

BATTERY

Inspect the battery for signs of leakage, damage to the terminals or casing, and loose connections. Refer to Section 4-2, BATTERY CHARGING for details on charging. Do not allow battery to drain completely, as this causes damage to the battery and may prevent proper charging. Only use a charger that meets the specifications described in Section 4-2, BATTERY CHARGING.

3 ENGINE AND TRANSMISSION

CONTENTS

3-1	ENGINE AND TRANSMISSION	18
	ENGINE AND TRANSMISSION COMPONENTS INSPECTION AND SERVICING	18
	CYLINDER	18
	CYLINDER REMOVAL	18
	CYLINDER INNER WALL WEAR INSPECTION	18
3-2	ENGINE AND TRANSMISSION	19
	PISTON SET	19
	PISTON PIN INSPECTION AND SERVICING	19
3-3	ENGINE AND TRANSMISSION	20
	PISTON RINGS INSPECTION AND SERVICING	20
	CONNECTING ROD END INSPECTION	20
	PISTON RINGS SET UP	20
	PISTON SET INSTALLATION	20
3-4	ENGINE AND TRANSMISSION	21
	CRANK CONNECTING ROD SET	21
	CRANKCASE AND CRANKSHAFT REMOVAL	21
3-5	ENGINE AND TRANSMISSION	22
3-6	ENGINE AND TRANSMISSION	23
	CRANKSHAFT AND CRANKCASE INSPECTION	23
	CRANKSHAFT AND CRANKCASE INSTALLATION	23
3-7	ENGINE AND TRANSMISSION	24
	VALVE MECHANISM INSPECTION AND SERVICING	24
	GENERAL INTRODUCTION	24
	VALVE CLEARANCE ADJUSTMENT	24
3-8	ENGINE AND TRANSMISSION	25
3-9	ENGINE AND TRANSMISSION	26
	CAMSHAFT	26
	CAMSHAFT REMOVAL	26
3-10	ENGINE AND TRANSMISSION	27
	CAMSHAFT INSPECTION	27
	CAMSHAFT INSTALLATION	27
	ROCKER ARM AND ROCKSHAFT	27
	ROCKER ARM AND ROCKSHAFT REMOVAL	27
3-11	ENGINE AND TRANSMISSION	28
	ROCKER ARM AND ROCKSHAFT INSTALLATION	28
	CAM CHAIN TENSIONER	28
3-12	ENGINE AND TRANSMISSION	29
	VALVE AND VALVE SPRING	29
	VALVE AND VALVE SPRING REMOVAL.	29
	VALVE AND VALVE SPRING INSPECTION	29
	VALVE AND VALVE SPRING INSTALLATION.	29

3-13	ENGINE AND TRANSMISSION	30
	VALVE GUIDE	30
	CLEANING CARBON ACCUMULATION OF THE VALVE GUIDE	30
	VALVE GUIDE REPLACEMENT	30
3-14	ENGINE AND TRANSMISSION	31
	VALVE SEAT	31
	VALVE SEAT WIDTH MEASUREMENT	31
3-15	ENGINE AND TRANSMISSION	32
	VALVE SEAT FINISHING	32
	VALVE SEAT TOUCHING POSITION INSPECTION	32
3-16	ENGINE AND TRANSMISSION	33
	VALVE AND VALVE SEAT LAPPING	33
	VALVE AND VALVE SEAT AIR IMPERMEABILITY INSPECTION	33
	LUBRICATION SYSTEM INSPECTION AND SERVICING	33
	GENERAL INTRODUCTION	33
3-17	ENGINE AND TRANSMISSION	34
	OIL SYSTEM INSPECTION AND REPLACEMENT	34
3-18	ENGINE AND TRANSMISSION	35
	ROTARY OIL PUMP	35
	OIL PUMP REMOVAL	35
3-19	ENGINE AND TRANSMISSION	36
	OIL PUMP INSPECTION	36
	OIL PUMP ASSEMBLY	36
3-20	ENGINE AND TRANSMISSION	37
	OIL PUMP INSTALLATION	37
3-21	ENGINE AND TRANSMISSION	38
	FUEL SYSTEM INSPECTION AND SERVICING	38
	CV CARBURETOR	38
3-22	ENGINE AND TRANSMISSION	39
	CARBURETOR IDLING ADJUSTMENT	39
	CARBURETOR REMOVAL	39
	CARBURETOR INSTALLATION	39
	VACUUM CHAMBER	39
3-23	ENGINE AND TRANSMISSION	40
	VACUUM CHAMBER REMOVAL	40
	VACUUM CHAMBER INSTALLATION	40
	AUTOMATIC SIDE STARTER (CHOKE)	40
	AUTOMATIC SIDE STARTER INSPECTION	40
3-24	ENGINE AND TRANSMISSION	41
	FLOAT CHAMBER	41
	FLOAT CHAMBER REMOVAL	41
	FLOAT CHAMBER INSPECTION	41
	FLOAT CHAMBER INSTALLATION	41
	FUEL LEVEL INSPECTION	41

3-25	ENGINE AND TRANSMISSION	42
	AIR CHECK VALVE (ACV)	42
	AIR CHECK VALVE REMOVAL	42
	AIR CHECK VALVE INSTALLATION	42
3-26	ENGINE AND TRANSMISSION	43
	STARTING MECHANISM INSPECTION AND SERVICING	43
	STARTER MOTOR	43
	STARTER MOTOR REMOVAL	43
3-27	ENGINE AND TRANSMISSION	44
	ARMATURE INSPECTION	44
	CARBON BRUSH INSPECTION	44
3-28	ENGINE AND TRANSMISSION	45
	STARTER MOTOR INSTALLATION	45
3-29	ENGINE AND TRANSMISSION	46
	REDUCTION MECHANISM	46
	REDUCTION GEAR INSPECTION	46
	STARTING CLUTCH REMOVAL	46
3-30	ENGINE AND TRANSMISSION	47
	STARTING CLUTCH INSPECTION	47
	STARTING CLUTCH INSTALLATION.	47
3-31	ENGINE AND TRANSMISSION	48
	STARTER RELAY INSPECTION	48
3-32	ENGINE AND TRANSMISSION	49
	BELT DRIVEN CVT MECHANISM INSPECTION AND SERVICING	49
	GENERAL INTRODUCTION	49
3-33	ENGINE AND TRANSMISSION	50
	DRIVE BELT PULLEY	50
	DRIVE BELT PULLEY REMOVAL	50
3-34	ENGINE AND TRANSMISSION	51
	DRIVE BELT PULLEY INSPECTION	51
3-35	ENGINE AND TRANSMISSION	52
	DRIVE BELT PULLEY INSTALLATION	52
3-36	ENGINE AND TRANSMISSION	53
	CLUTCH	53
	CLUTCH REMOVAL	53
	CLUTCH INSPECTION	53
	CLUTCH DISASSEMBLY	53
3-37	ENGINE AND TRANSMISSION	54
	CLUTCH INSTALLATION	54
	DRIVEN BELT PULLEY	54
	DRIVEN BELT PULLEY REMOVAL	54

3-38	ENGINE AND TRANSMISSION	55
	DRIVEN BELT PULLEY INSPECTION	55
	DRIVEN PLATE BEARING REPLACEMENT	55
3-39	ENGINE AND TRANSMISSION	56
	DRIVEN BELT PULLEY INSTALLATION	56
3-40	ENGINE AND TRANSMISSION	57
	TRANSMISSION BELT	57
	TRANSMISSION BELT INSPECTION	57
	TRANSMISSION	57
3-41	ENGINE AND TRANSMISSION	58
	TRANSMISSION ASSEMBLY	58
3-42	ENGINE AND TRANSMISSION	59
3-43	ENGINE AND TRANSMISSION	60
3-44	ENGINE AND TRANSMISSION	61
3-45	ENGINE AND TRANSMISSION	62
3-46	ENGINE AND TRANSMISSION	63
	OIL SYSTEM INSPECTION AND SERVICING (W/ OIL FILTER)	63
	OIL FILTER REPLACEMENT	63

3-1 ENGINE AND TRANSMISSION

ENGINE AND TRANSMISSION COMPONENTS INSPECTION AND SERVICING

CYLINDER

CYLINDER REMOVAL

NOTE:

The removal can be done with engine on the vehicle body.

- Remove cylinder head.
- Remove cylinder.
- Remove cylinder gasket, bolts
- Remove cylinder gasket.

CAUTION!

Do not damage the area of the cylinder.
Do not drop sundries, such as cylinder gasket material into the crankcase.

CYLINDER INNER WALL WEAR INSPECTION

Use a bore diameter dial gauge to measure the degree of wear. The measure point is divided into three sectional planes in the axial direction: upper, middle, lower; measure every plane each time on the mutually perpendicular directions (X, Y), the measured least dimension is the cylinder bore; at the most

upper position measured is the largest diameter, and at the most lower position measured is the smallest diameter, their difference is the cylindricity of the cylinder. At the same

cross section, measured the difference of diameter between two points mutually perpendicular; which is the circularity of the cylinder.

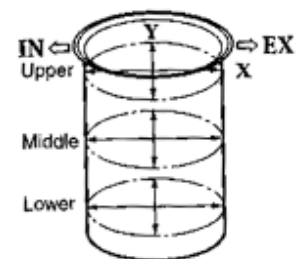
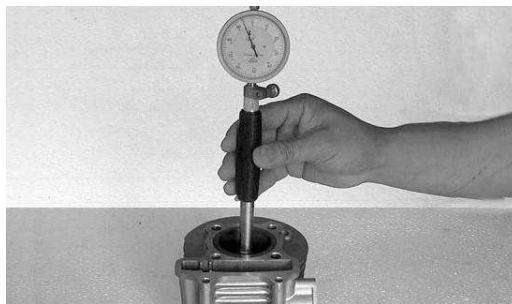

3-2 ENGINE AND TRANSMISSION

IN ORDER TO MAKE THE MEASURING POINT PERPENDICULAR WITH THE BORE AXIS OF THE CYLINDER, AND TO ENSURE THE PRECISION OF THE MEASUREMENT, THE BAR OF THE GAUGE CAN BE SLIGHTLY SWUNG IN THE DIRECTION OF THE GAUGE BAR, AND TAKE THE SMALLEST READING NUMBER AS THE RESULT.

In the situation without a dial gauge, a feeler gauge can be used to make relativity measurement, that is to put a new piston into the cylinder, and use the feeler gauge to measure the gap between the piston skirt and the cylinder wall, then figure out the abrasion loss of the cylinder. If the circularity of the cylinder exceeds the limit, then a cylinder reboring machine should be used to rebore the cylinder, and enlarge its diameter by 0.5mm or 1.00mm, then fit the piston and piston ring which size are also enlarged. If the wear is too severe and cannot be reworked, then a new cylinder should be installed.

Cylinder bore	57.4mm
Cylindricity	0.05mm
Circularity	0.05mm

PISTON SET

PISTON PIN INSPECTION AND SERVICING

Insert the piston pin horizontally into the piston pinhole, and inspect the clearance between piston and piston pin.

Service limit	0.02mm
---------------	--------

If the free play is too much, the worn condition of piston pin and piston pinhole must be inspected respective.

Measuring the external diameter of piston pin.

Service limit	14.96mm
---------------	---------

If the result is less than Service limit, it should be replaced.

After replacement, the clearance between piston pin and piston pinhole must be assured to comply with the requirement.

Measuring the inner diameter of piston pin.

Service limit	15.04mm
---------------	---------

If the result is more than the Service limit, it should be replaced.

After replacement, the clearance between the holes of piston pin must be assured to comply with the requirement.

3-3 ENGINE AND TRANSMISSION

PISTON RINGS INSPECTION AND SERVICING

Inspect if there is a flaw, serious wear, or serious conglutination, etc. on the piston ring. If there is, it should be replaced.

The piston ring's lateral clearance and notch clearance are too large or too small with both cause malfunctions, so it must be measured.

Measure the clearance of piston ring in the piston ring groove. This clearance is the piston ring's lateral clearance.

First ring	0.09mm
Second ring	0.09mm

CONNECTING ROD END INSPECTION

Put the piston pin and bearing into the connecting rod end; inspect the degree of tightness of the piston pin in connecting rod end.

Measure the inner diameter of the connecting rod end.

Service limit	15.06mm
---------------	---------

When the abrasion of the bore exceeds the limitation, it should be replaced.

PISTON RINGS SET UP

Before setting up first apply oil on every piston ring. Then enlarge piston rings. At the same time, cover them on the piston and move downwards gradually, until piston rings fall into the ring groove. The ring gaps should be aligned at 90 degree intervals.

Ring order:

- Top: Barrel Ring (slightly rounded edges)
- Middle: Square/Taper Ring (no rounding on edges)
- Bottom: Scraper/Cutter Rings (thin ring, scraper, thin ring)

PISTON SET INSTALLATION

- Remove the gasket attached to the crankcase.
- Mount piston onto the small end of the connecting rod.

The top of the piston with "IN" mark should be mounted towards the direction of the inlet port (if the mark is "EX", then it should be mounted towards the direction of the exhaust port).
--

Mounting piston pin and piston pin clip

Apply oil on the piston pin to lubricate it. Cover a piece of cloth on the crankcase port to avoid the piston pin clip from dropping into the crankcase.

3-4 ENGINE AND TRANSMISSION

CRANK CONNECTING ROD SET

The connecting rod is the component that links the piston and crankshaft.

The picture shows the structure and assembling relations of the crank connecting rod component.

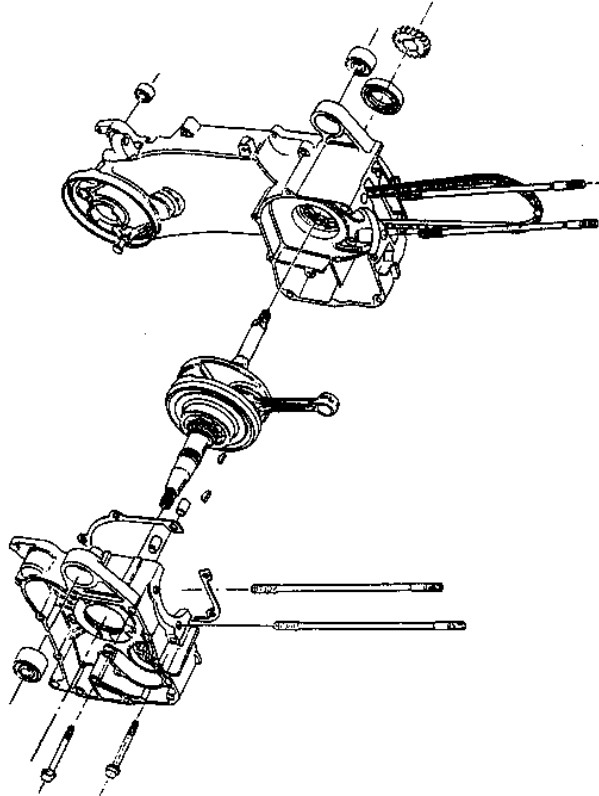

FIGURE 1 CRANK CONNECTING ROD COMPONENTS

CRANKCASE AND CRANKSHAFT REMOVAL

Before removing the crankcase and crankshaft, perform the following procedures:

- Remove the engine.
- Remove the cylinder cover.
- Remove the cylinder.
- Remove the piston.

- Remove the drive plate and the driven plate.
- Remove the AC generator.
- Remove the starting motor.
- Remove the oil pump.
- Remove the cam chain tensioner bolt.
- Remove the cam chain tensioner.
- Use special tools to remove the starting driven gear.

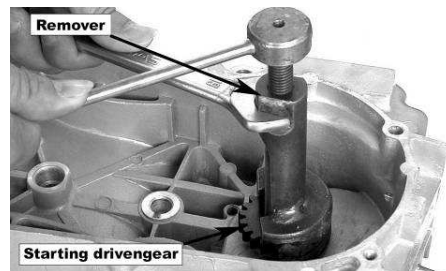
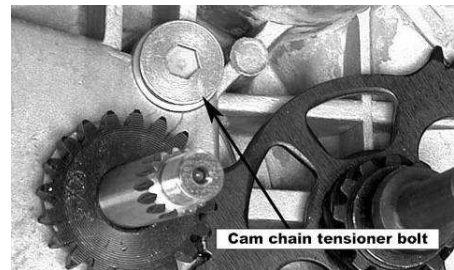

3-5 ENGINE AND TRANSMISSION

- Remove the crankcase positioning bolts.
- Separate the right crankcase and the left crankcase.

The joint face cannot be damaged.

- Remove the gasket and the dowel pins.

- Remove the crankshaft from the crankcase.
- Take out the cam chain.

- Remove the gasket on the crankcase joint face, pay attention not to damage the joint face.

- Remove the oil seal from the left crankcase.

- Remove the oil seal from the right crankcase.

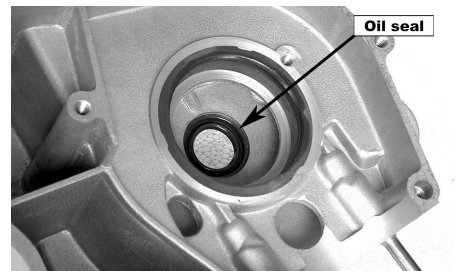
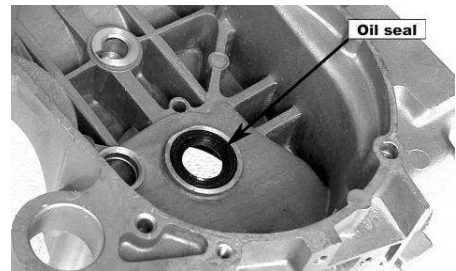
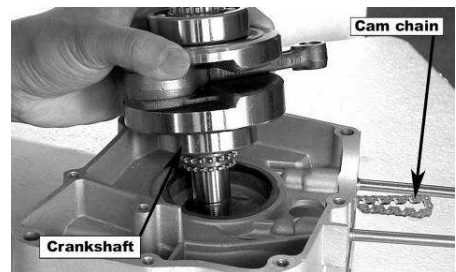
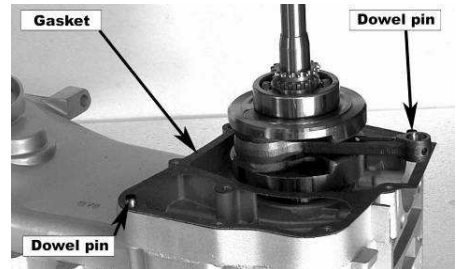
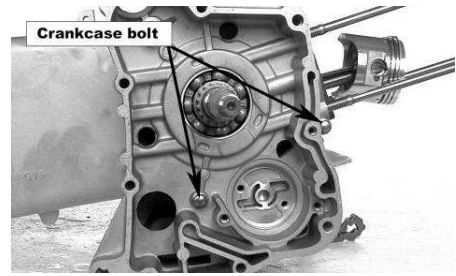

3-6 ENGINE AND TRANSMISSION

CRANKSHAFT AND CRANKCASE INSPECTION

Replace the entire crankshaft assembly if serious wear is found while inspecting. Measuring the axial trend clearance of the big end of the connecting rod

When measuring place the larger side of the connecting rod close to the crank, and insert the feeler gauge between the other side and the crank, to measure the end play.

Service limit	0.55mm
---------------	--------

Measuring the radial trend (X,Y) clearance of the big end of the conrod.

Service limit	0.05mm
---------------	--------

MEASURING THE MAIN SHAFT JOURNAL JUMP OF THE CRANKSHAFT.

If the crank journal jump is too much it will cause the engine to shake abnormally, and shorten the life of the engine, so it must be examined carefully when inspecting.

Service limit	0.10mm(A=90)
	0.10mm(B=105)

Examine if there is any loose, or unusual sound when the crank journal bearing turns. If there is, the whole set should be changed.

After cleaning the crankcase, inspect if there is any damage.

Inspect if the joint face of the crankcase is smooth and clean, and notice if it will affect the sealing performance between the left and right crankcase while reassembling.

After the above inspection, use an oilstone to finish the crankcase if it has some surface damage.

Replace the cover if damage is too severe.

Because the right and left crankcase axle hole must be concentric, so generally they must be replaced at the same time.

CRANKSHAFT AND CRANKCASE INSTALLATION

- Mount the crankcase oil seal.
- Put the cam chain into the left crankcase..
- Put the crankshaft into the left crankcase.

Pay attention to avoid the cam chain damaging the oil seal.



- Mount new dowel pins and gasket on the left crankcase. Join the right crankcase and left crankcase together.

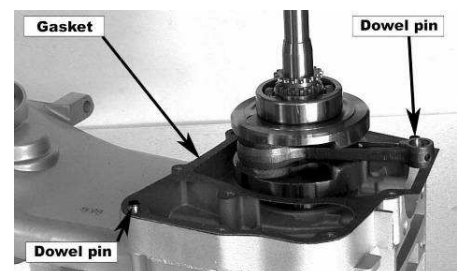

3-7 ENGINE AND TRANSMISSION

- Tighten the crankcase positioning bolts.

Tightening torque	1.98 lbs.m
-------------------	------------

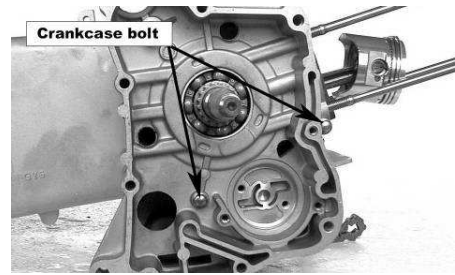

- Mount the starting driven gear.

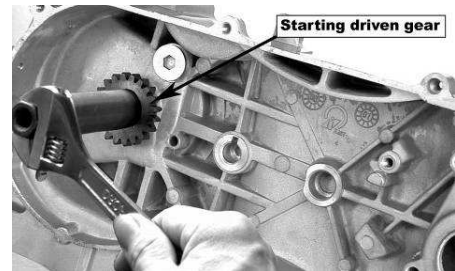

- Mount the cam chain tensioner
- Mount the new O-ring on the cam chain tensioner bolt.
- Apply some oil on the O-ring.
- Tighten the cam chain tensioner bolt.

The O-ring must be mounted in the groove.

VALVE MECHANISM INSPECTION AND SERVICING

The picture shows the common valve train of a four-stroke engine. This is one kind of overhead valve train. Its intake port, exhaust port, camshaft are all located in the cylinder head; the valves bottom up over the combustion chamber.

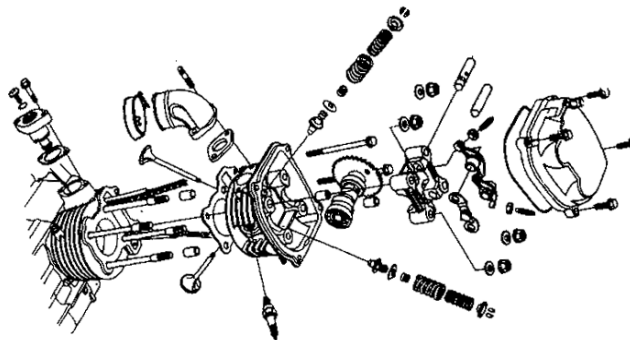

GENERAL INTRODUCTION

The four-stroke engine completes its four strokes with two piston strokes.

- Intake stroke
- Compression stroke
- Expansion stroke
- Exhaust stroke

VALVE CLEARANCE ADJUSTMENT

Valve clearance is an important technical parameter in the valve train, in order to make sure that during any conditions, especially when the engine is heated, the valve can close tightly. When the valve is in the cold condition, there must be certain clearance kept. This clearance is called valve clearance.

3-8 ENGINE AND TRANSMISSION

When the engine is running, the valve clearance is demanded neither too big, nor too small. So, valve clearance adjustment is an important procedure in the valve train maintenance.

Inspection and adjustment must be with a cool engine (below 35°C).

- Remove the cylinder head cover

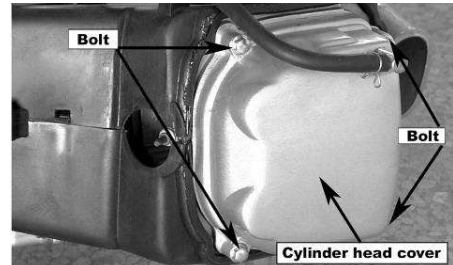

- Turn the cooling fan clockwise until the mark of the timing drive sprocket on the camshaft is in top dead center, and the "T" symbol (or other mark) of the magneto flywheel aligns to the crankcase mark.

The crankshaft should co-rotate, or the exhaust port may not be adjusted.

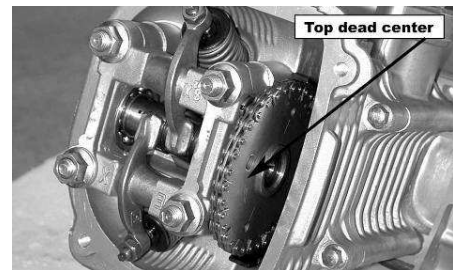

When adjusting, loosen the locknuts, adjust the bolts with a valve-adjusting wrench, turn clockwise, the valve clearance decreases, and turn counterclockwise, the valve clearance increases. Then, put a feeler gauge with specific size between valve and rocket to check for correct clearance. Take out the feeler gauge, tighten the locknuts, and then inspect the valve clearance again.

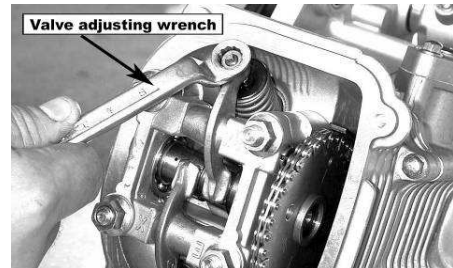

Sometimes, when tightening the locknuts the clearance will change, so it must be rechecked for the proper clearance.

Valve clearance	0.08 ~ 0.12mm
-----------------	---------------

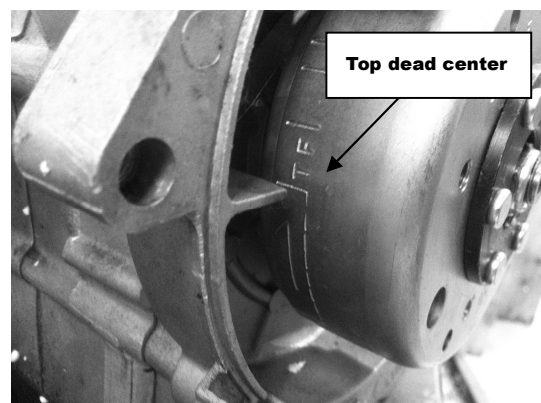

3-9 ENGINE AND TRANSMISSION

CAMSHAFT

The camshaft is the main driving unit of the valve train. There are the air inlet cam, the exhaust cam, and the cam journal on the shaft. The camshaft controls the intake and exhaust valve to open and close at the correct time. Camshaft wear will affect engine performance and cause excessive noise.

CAMSHAFT REMOVAL

- Loosen valve cover bolts and remove cover.
- Remove the cam chain tensional bolt cap, and remove the O-ring.
- Tighten the cam chain tensioner adjusting bolt clockwise.
- Turn the flywheel counterclockwise to make the “T” mark on the flywheel align with the mark on the crankcase. When the hole on the cam chain (timing drive chain wheel) is up, it is the top dead center position.
- Remove the cylinder head positioning bolt.
- Remove the camshaft holder bolt cap, washer.
- Remove the camshaft holder and dowel pin.
- Remove the cam chain wheel from the cam chain, and remove the camshaft.

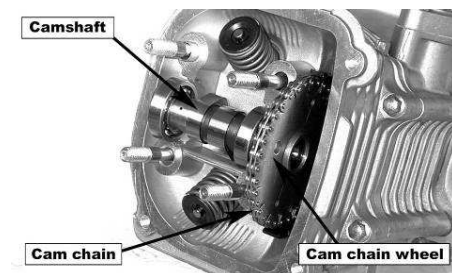
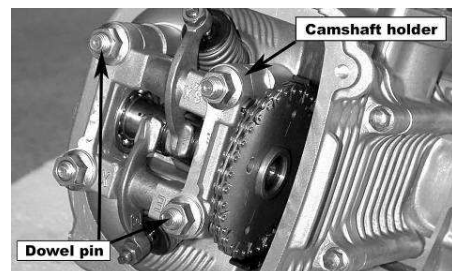
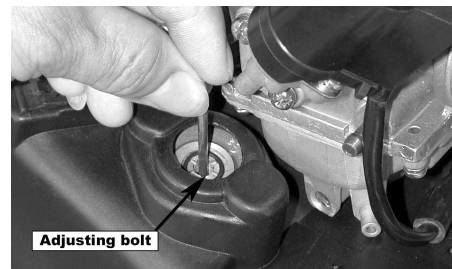
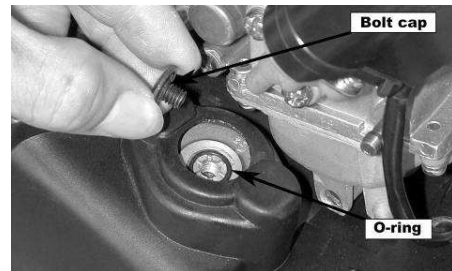

3-10 ENGINE AND TRANSMISSION

CAMSHAFT INSPECTION

Inspect the camshaft bearings for play. If there is play, replace the whole set.

Inspect cam surface for damage.

Measure the height of the cam.

Inlet cam	25.96mm
Exhaust cam	25.815mm

CAMSHAFT INSTALLATION

- Rotate the flywheel to align the “T” mark on the flywheel with the camshaft mark, and ensure that the round hole on the cam chain wheel is up, and the left and right sit parallel with the cylinder head (the lobes of the camshaft are down). Then install the camshaft on the cylinder head.
- Mount the cam chain on the chain wheel.
- Install the dowel pins.
- Mount the camshaft holder, washer, bolt cap on the cylinder head.
- Tighten the cylinder head bolt and nut.

While installing, first apply some oil on the thread part of the camshaft holder bolt.

The camshaft nuts should be tightened diagonally in a 3-step process.

After installing, adjust the valve clearance.

- Turn the cam chain tensioner-adjusting bolt counter-clockwise, and release the lock.
- Apply oil on the new O-ring.
- Mount and tighten the cam chain tensioner cover bolt.

The O-ring must be mounted proper in the groove.

- Replace the valve cover gasket, and mount the cover.

The valve cover gasket must be mounted properly in the groove.

- Tighten the valve cover-positioning bolt.

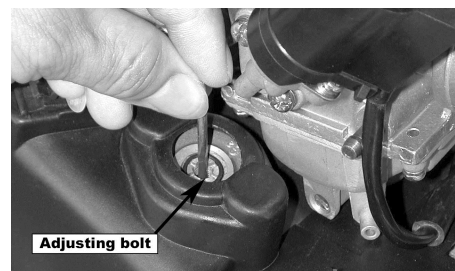

ROCKER ARM AND ROCKSHAFT

ROCKER ARM AND ROCKSHAFT REMOVAL

- Remove the camshaft holder.
- Take out the rockshaft by removing the bolt.
- Remove the rocker arm.
- **ROCKER ARM AND ROCKSHAFT INSPECTION**
- Inspect if there is any abrasion or damage on the rocker arm and rockshaft or if the oil hole is clogged.

3-11 ENGINE AND TRANSMISSION

If there is abrasion on the surface of the rocker arm, the camshaft should also be inspected.

Measuring the inner diameter of the rocker arm.

Service limit	10.04mm
---------------	---------

Measuring the outer diameter of the rockshaft.

Service limit	9.96mm
---------------	--------

ROCKER ARM AND ROCKSHAFT INSTALLATION

Find the “EX” mark on the camshaft holder, then mount the exhaust port rocker arm and the rockshaft. After that, mount the inlet port rocker arm and rockshaft.

Apply some oil on the rockshaft before mounting it on.

CAM CHAIN TENSIONER

The chain tensioner must be in good working order for proper chain tension.

1. Cam chain
2. Cam chain tensioner
3. Cam chain tensioner lifter
4. Gasket
5. Cam chain tensioner pivot
6. Cam chain guide
7. Bolt
8. Nut
9. O-ring
10. O-ring

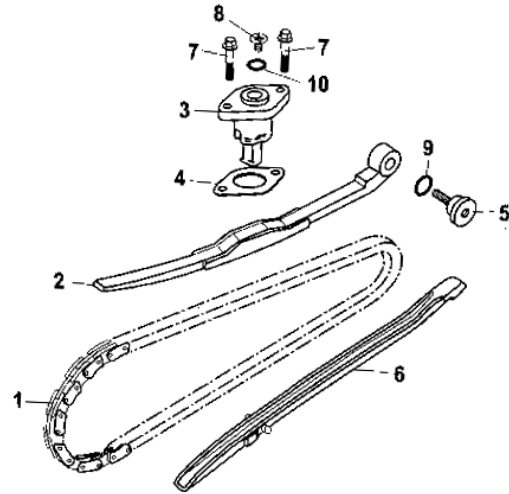

The operational principle of the tensioner is as shown in the picture.

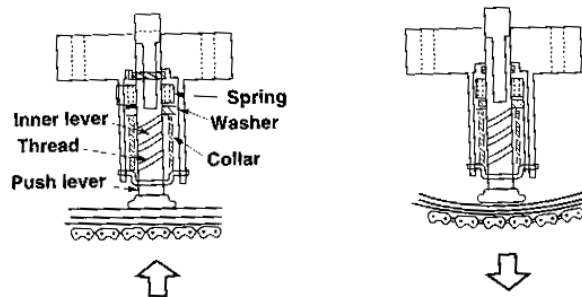

As for the adjustment of the cam chain tensioner, clockwise is tightening, and counterclockwise is loosening.

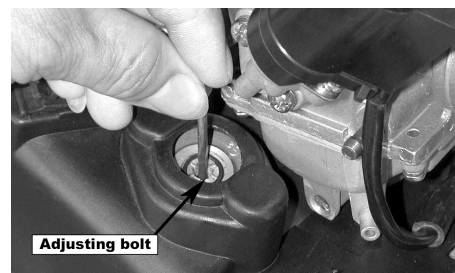

3-12 ENGINE AND TRANSMISSION

VALVE AND VALVE SPRING

VALVE AND VALVE SPRING REMOVAL.

Remove the cylinder head.

- Remove the valve cotter with the valve compressor.
- Remove the upper spring race, valve spring, lower spring race, valve stem oil seal etc in turn.
- Remove the valve from the other side.

The removed parts should be placed properly in order. It's better to place the intake valve parts and exhaust valve parts separately.

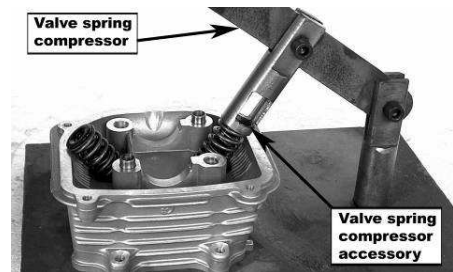

VALVE AND VALVE SPRING INSPECTION

Inspect to see if the valve is bent or burned.

Inspect if the action is smooth between the valve and the valve guide.

Measure the outer diameter of the valve stem.

Service limit	4.94mm
---------------	--------



Measure the free length of the inner and outer valve spring.

Valve	Inlet valve	Exhaust valve
Inner spring	31.2mm	31.2mm
Outer spring	34.1mm	34.1mm



VALVE AND VALVE SPRING

INSTALLATION.

- Mount the spring retainer, valve guide oil seal.

It's recommended to replace the valve guide oil seal with a new one.

- After applying oil on the valve stem mount it into the valve guide.
- Mount the inner and outer valve springs.
- Mount the valve locker with a spring compressor.

When mounting, the twisting direction of the inner and outer springs must be opposite, and cannot be the same.

- Tap at the valve gently two or three times with a rubber hammer to make the valve and the valve lock match well.

Do not damage the valve.

3-13 ENGINE AND TRANSMISSION

VALVE GUIDE

Carbon accumulation on the valve guide will make valve movement rough, causing the valve to not open or close properly.

Valve guide abrasion is one of the causes of white smoke from the exhaust pipe

CLEANING CARBON ACCUMULATION OF THE VALVE GUIDE

- Remove the valve and springs etc.
- Clean the carbon accumulation with a valve guide reamer.

Generally only turn right when using the reamer, and do not push in or out directly with the reamer.

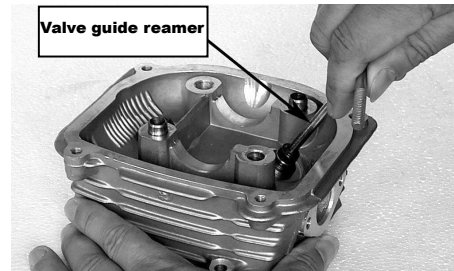

Valve guide inner diameter measurement

Service limit	5.03mm
---------------	--------

- Calculate the clearance between the valves stem and the valve guide.
(The inner diameter of the guide subtracts the outer diameter of the valve stem).

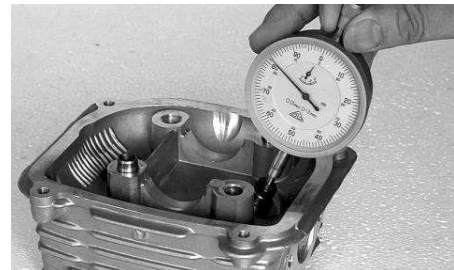

Valve	Inlet valve	Exhaust valve
Service limit	0.08mm	0.10mm

When abrasion of the valve guide exceeds the use limit, it should be replaced; after replacing a new valve guide, the valve retainer must be adjusted.

VALVE GUIDE REPLACEMENT

- Heat the cylinder head to 100 ~ 150°C

The cylinder head must be wholly and quickly heated to the specific degree, and cannot be heated partly or it'll cause the cylinder head to distort. The temperature must be very high, so two technicians are recommended for safety purposes.

- Tap the valve guide out with a valve guide remover or similar tool.

Do not damage the cylinder joint face.



3-14 ENGINE AND TRANSMISSION

- After tapping the valve guide, you need to trim it with a reamer.

When using the reamer, cutting oil must be used. The reamer can only be turned right, do not push in or out directly.

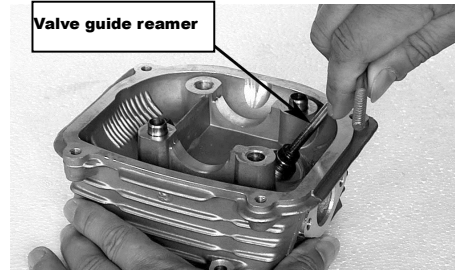
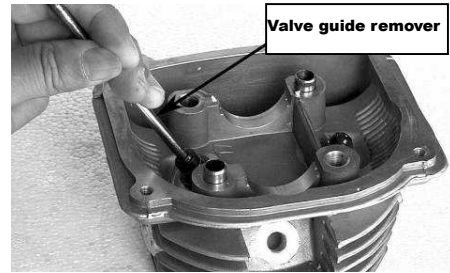

- Clean the cylinder head, and eliminate the scraps generated while ramming.

VALVE SEAT

The relative position between the valve seat and the working surface of the valve is very important for the valve to seal properly.

VALVE SEAT WIDTH MEASUREMENT

Clean the carbon accumulation in the combustion chamber.

Measure the width of the valve seat with a vernier caliper.

Standard	0.6 – 1.2mm
Service limit	1.8mm

When abrasion causes the valve seat width to be uneven, too wide, or too narrow, it will result in bad contact between the valve and the valve seat and the valve will not seal tightly. At this time, it must be reamed with a customized valve seat milling cutter.

The valve seat milling cutter is a customized trimming tool for the valve seat, and it has three cutting angles, 32°, 45°, and 60°.

While trimming, press the valve seat milling cutter to make rotary motion with 40 ~ 50 N force.

Some oil must be applied on the valve seat milling cutter, to eliminate scrapping when trimming.

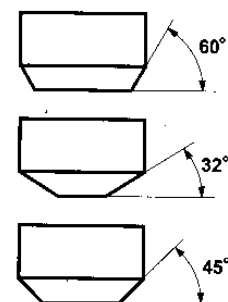
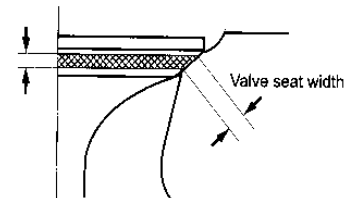

3-15 ENGINE AND TRANSMISSION

VALVE SEAT FINISHING

- Ream out the defects on the working surface with a 45° coarse tooth milling cutter.

Do not ream too much.

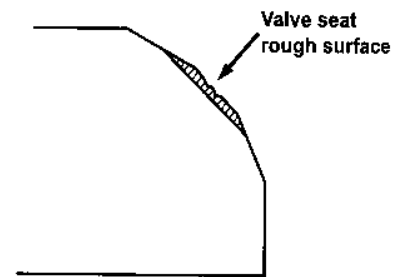

- Ream the upper angles of the valve seat working surface with a 30° milling cutter.

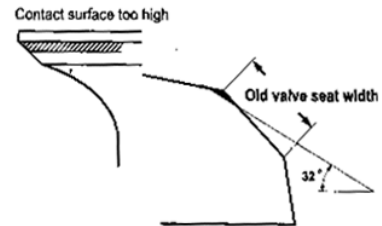

- Ream the lower angles of the valve seat working surface with a 60° milling cutter.

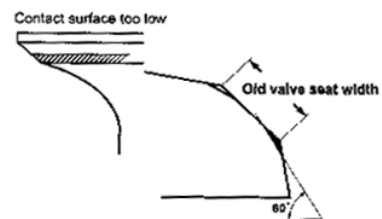

- Finally, ream the valve seat to the specific seat width with a 45° milling cutter.

VALVE SEAT TOUCHING POSITION INSPECTION

Apply a thin layer of oil on the valve seat and put the valve on the seat. Rotate gently, then take out the valve and observe the contact surface on the valve face. If the contact position is too high, cut out some of the upper part of the valve seat with a 32° milling cutter to reduce the working face of the valve seat.

If the contact position is too low, then cut out some of the lower part of the valve seat with a 60° milling cutter to raise the working face of the valve seat.

Finally, mill the working face of the valve seat to the specific width with a 45° milling cutter.

If the valve seat still cannot contact evenly with the valve after trimming, the valve should be revised or replaced.

3-16 ENGINE AND TRANSMISSION

VALVE AND VALVE SEAT LAPPING

After finishing the valve seat, the valve and seat should be lapped in order to make them seal properly.

Spread a thin layer of silicon carbide on the working level of the valve, and use a valve suction cup tool. Then repeatedly rotate the valve suction cup to lap the valve and valve seat evenly, until they match tightly.

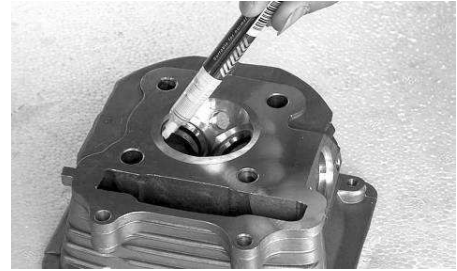

Before lapping, clean the valve, valve seat and valve guide.

When lapping do not use too much force.

During lapping, do not drop any silicon carbide into the place between the valve lever and the valve guide.

VALVE AND VALVE SEAT AIR IMPERMEABILITY INSPECTION

After lapping the valve and valve seat, the air impermeability of the joint surface should be inspected.

Method one: Same as the method of “VALVE SEAT TOUCHING POSITION INSPECTION”.

Method two: Evenly draw several lines on the working surface of the valve with a pencil. Put the valve into the valve seat. If the lines are all broken after turning $1/8 \sim 1/4$, then the air impermeability is good.



Method three: Mount the valve on the cylinder head, and fill the inlet and exhaust vent with nonflammable solvent, and preserve for 5 minutes. If there is no leaking, the valve is seated correctly.

LUBRICATION SYSTEM INSPECTION AND SERVICING

GENERAL INTRODUCTION

The picture shows the functional diagram of the lubrication system. After the lubrication oil crosses the filter screen, the rotator oil pump pumps it. Some of it goes into the big end of the connecting rod, and splashes on the cylinder wall and the small end of the connecting rod. The other goes through some oil passages, such as the shaft neck of the camshaft and splashes on the cam rockshaft and cam chain. The lubrication oil that falls back into the oil groove can be recirculated.

3-17 ENGINE AND TRANSMISSION

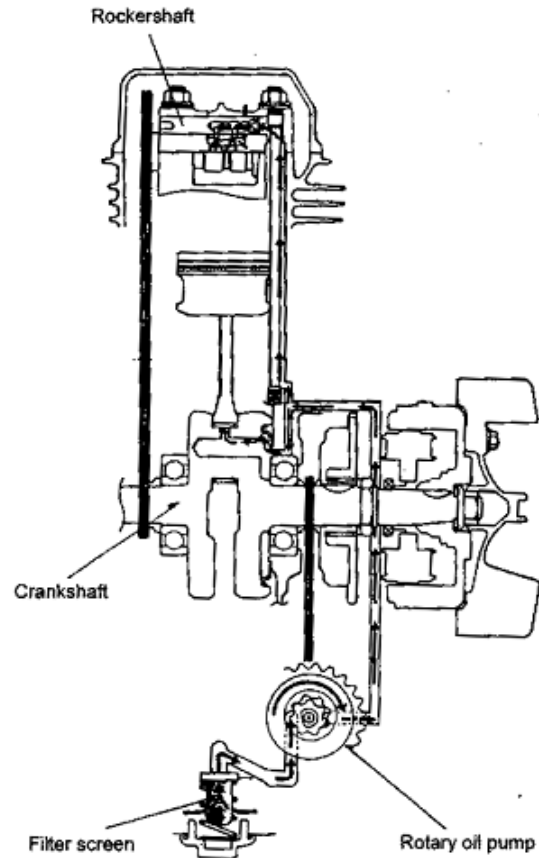

OIL SYSTEM INSPECTION AND REPLACEMENT

- Tighten the dipstick
- Remove the oil screen cap to let the oil flow out. When oil and engine are cool, remove the oil screen.
- Inspect if there is any damage of the screen and O-ring, if so, it should be replaced.
- Mount the oil screen and the screen covers and tighten the cover.
- Fill oil and test, according to Section 2-5 ENGINE OIL.

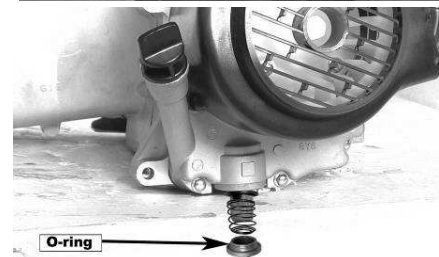

3-18 ENGINE AND TRANSMISSION

ROTARY OIL PUMP

The oil pump is the critical component of the lubrication system, so it should be inspected, maintained periodically, and should be replaced as a unit when damaged seriously.

OIL PUMP REMOVAL

- Remove the flywheel of the magneto.
- Remove the stator coil, trigger winding.
- Remove the right crankcase cover bolts and remove the right crankcase cover.
- Remove the gasket, dowel pins.
- Remove the starting reduction gear, starting clutch.
- Remove the oil pump partition plate positioning bolts, and remove the oil pump partition plate.
- Remove the oil pump driving gear nuts, and remove the driving gear, chain.
- Remove the oil pump positioning bolts, and remove the oil pump assembly.

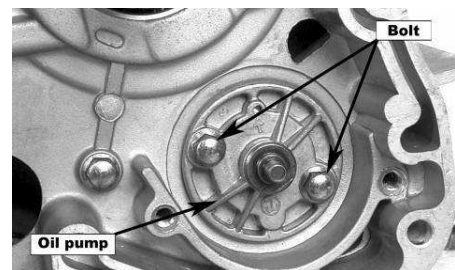
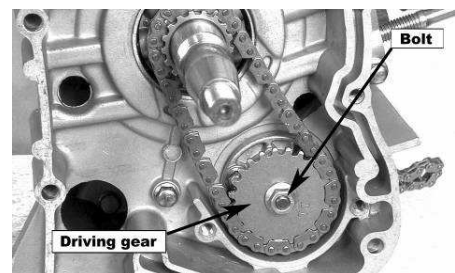
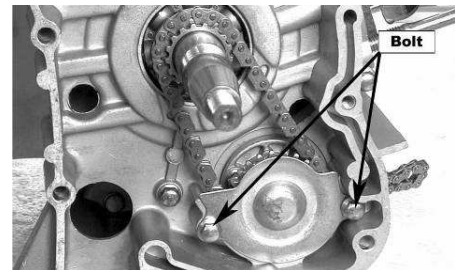
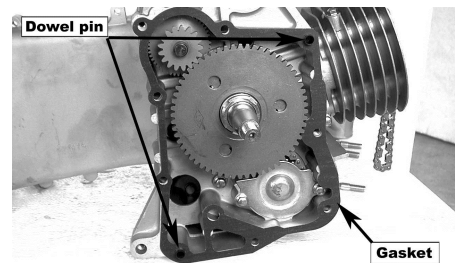
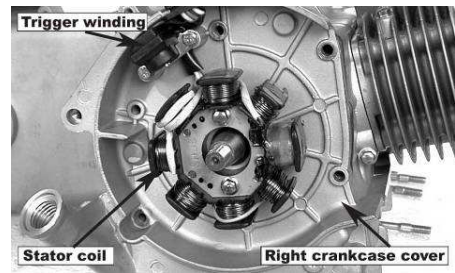

3-19 ENGINE AND TRANSMISSION

OIL PUMP INSPECTION

Remove the screws, and disassemble the oil pump.

Inspect the clearance between the oil pump body and the outer rotator.

Service limit	0.12mm
---------------	--------

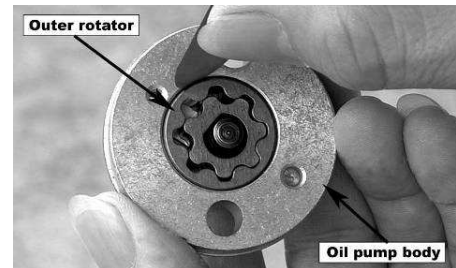

Inspect the clearance between the inner rotator and the outer rotator.

Service limit	0.12mm
---------------	--------

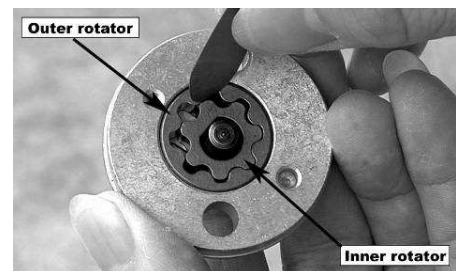

Inspect the clearance between the rotator plane and the oil pump.

Service limit	0.20mm
---------------	--------

If the inspection result exceeds the above stated service limit, the whole set should be replaced.

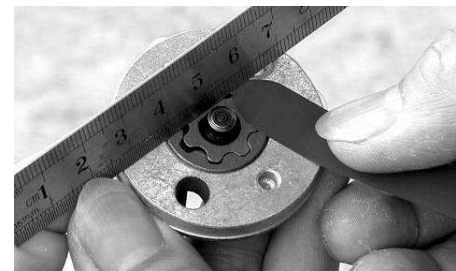

OIL PUMP ASSEMBLY

- Assemble the inner and outer rotators of the pump, and mount the oil pump shaft.

When assembling, align the unfilled corner of the oil pump shaft with the corner of the inner rotator, and then mount.

- Mount the dowel pin.
- After aligning the oil pump plate with the dowel pin, it can be installed.
- Tighten the oil pump plate bolts.
- After assembling, gently turn the oil pump shaft, and make sure the oil pump can turn smoothly.

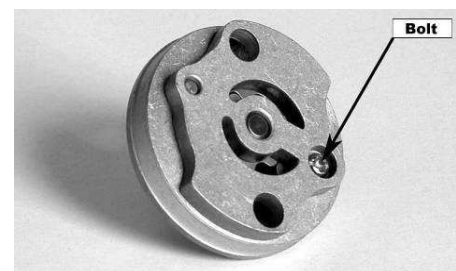
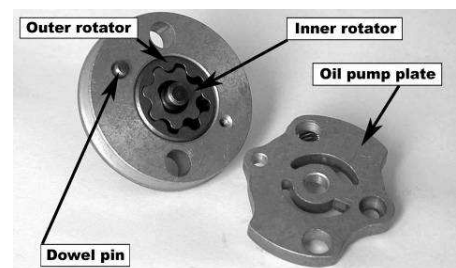

3-20 ENGINE AND TRANSMISSION

OIL PUMP INSTALLATION

- Install the oil pump on the crankcase.

Before installing, fill the oil pump with oil. When installing, the arrow of the oil pump body must be upwards.

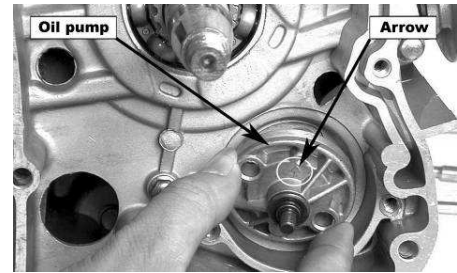

- Tighten the oil pump positioning bolts.

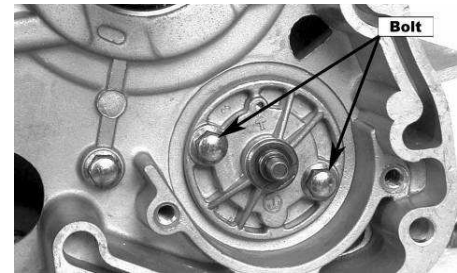

- Align the oil pump driving gear with the oil pump shaft unfilled corner, then mount the driving gear, chain.
- Mount the driving gear-positioning nut and tighten it.

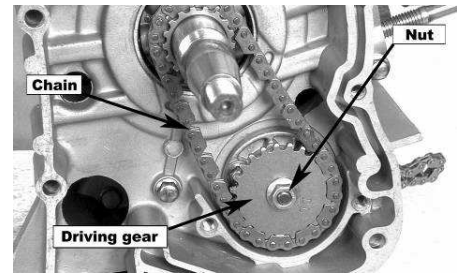

- Install the partition board and tighten bolts.

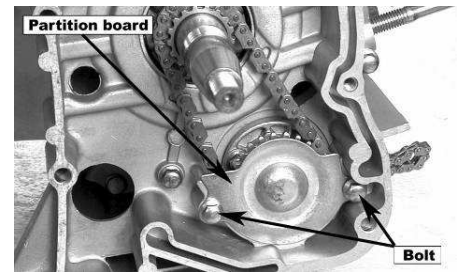

- Install the starting reduction gear, starting clutch.
- Mount the gasket, dowel pins.
- Mount the right crankcase cover-positioning bolt.
- Mount the trigger winding and the stator coil.
- Tighten the right crankcase cover-positioning bolt.

The bolt should be gradually diagonally tightened in two to three steps. After finishing the installation, inspect for any oil leaks.

3-21 ENGINE AND TRANSMISSION

FUEL SYSTEM INSPECTION AND SERVICING

CV CARBURETOR

The CV carburetor is a constant vacuum carburetor.

The picture shows the structure of the CV carburetor.

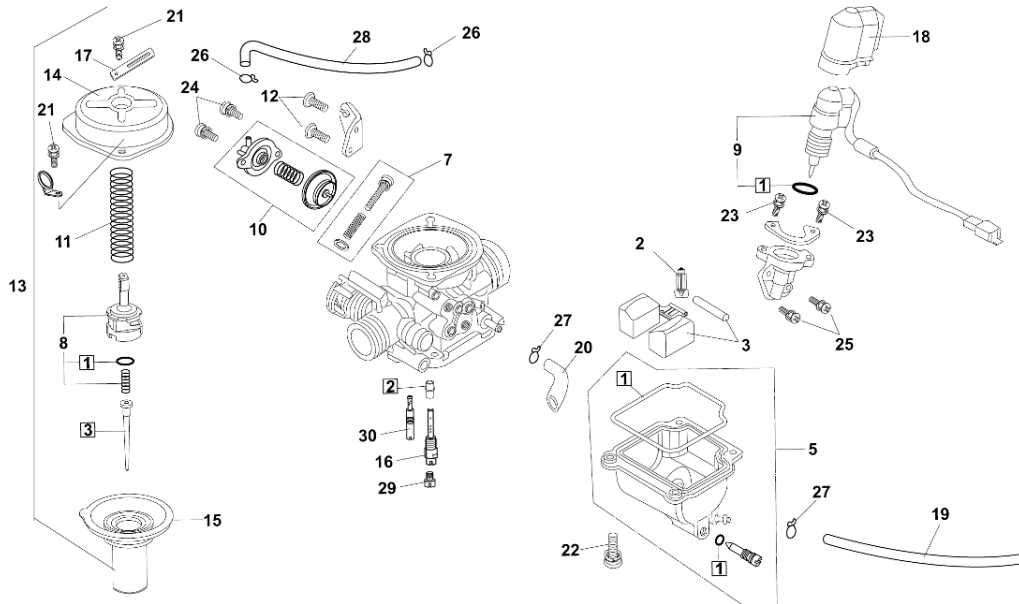

- | | | |
|-------------------------------|-----------------------------|------------------|
| 1. Gasket set | 11. Compression coil spring | 21. Screw |
| 2. Float valve set | 12. Screw | 22. Screw |
| 3. Needle jet set | 13. Carburetor assy | 23. Washer screw |
| 4. Float set | 14. Top comp | 24. Washer screw |
| 5. Float chamber set | 15. Vacuum piston comp | 25. Washer screw |
| 6. Screw set A | 16. Needle jet holder | 26. Clip |
| 7. Screw set B | 17. Plate clip | 27. Clip |
| 8. Valve plate set | 18. Holder cap | 28. Tube |
| 9. Electric choke /Auto choke | 19. Tube A | 29. Main jet |
| 10. Air cut valve set | 20. Tube B | 30. Slow jet |

3-22 ENGINE AND TRANSMISSION

CARBURETOR IDLING ADJUSTMENT

AIR ADJUSTING SCREW ADJUSTMENT

First, turn the air adjusting screw all the way in. Then, turn the screw back out by the prescribed number of turns. Each turn is one complete turn, 360 degrees.

Turn out number of turns	2 3/4 – 2 1/4
--------------------------	---------------

Ensure the rear wheels are safely off the ground. Start the engine and adjust the throttle adjusting screw to the prescribed idle rpm (1500 +/-150rpm).

Left and right adjust the air adjusting screw slightly to find the highest position of the rpm. Allow a few seconds after each adjustment.

Add throttle quickly and gently to full throttle, and return throttle immediately. Observe 10 to 15 minutes to ensure the idle speed remains the same.

CARBURETOR REMOVAL

- Remove the body cover.
- Remove the automatic choke lead wire.
- Loosen the fuel drain bolt, and drain the fuel in the float chamber. Remove the fuel line and the vacuum hose.
- Loosen the throttle cable-adjusting nut and positioning nut; remove the throttle cable.
- Loosen the carburetor air inlet vent clip and the inlet manifold clip; remove the carburetor.

CARBURETOR INSTALLATION

Reverse the removal procedure for installation.

After installing, make sure all carburetor linkage and cables are in correct position, make sure carburetor is in idle position,

VACUUM CHAMBER

The picture shows the structure of the vacuum chamber of the CV carburetor.

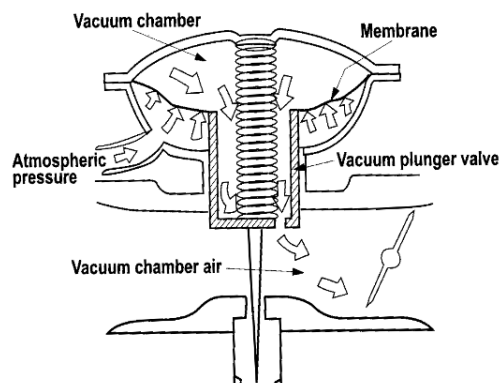

3-23 ENGINE AND TRANSMISSION

VACUUM CHAMBER REMOVAL

- Remove the vacuum cover bolt, and remove the vacuum cover.

Remove slowly to prevent the spring from ejecting.

- Take out the spring, the vacuum membrane and the plunger.
- Press down the holding clamp of the needle valve top, and turn left to take out the clamp.
- Take out the spring, needle valve.

Do not damage the vacuum membrane.

- Inspect if the needle valve is worn or not.
- Inspect if there is damage on the vacuum membrane.
- Inspect if the plunger is damage.

VACUUM CHAMBER INSTALLATION

- Mount the plunger, vacuum membrane into the carburetor body.
- Push the plunger upwards in the direction of the vacuum chamber cover to make the carburetor jet tube in the condition of completely open.
- Put the spring in.
- Align the bulge part of the vacuum membrane with the fillister of the carburetor body, and then mount the vacuum chamber cover.
- Tighten the bolt.

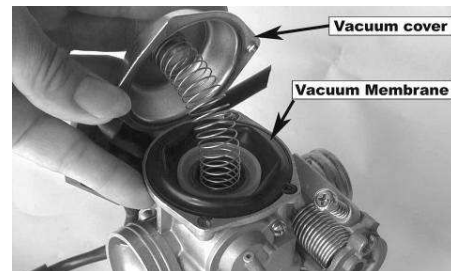
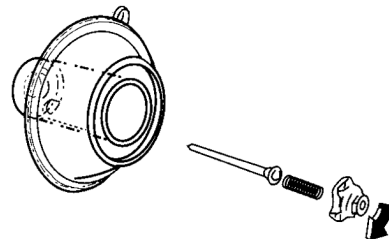
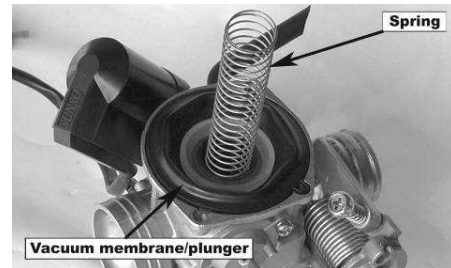
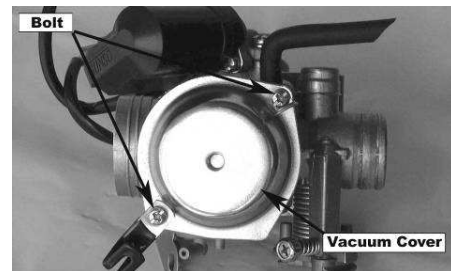

AUTOMATIC SIDE STARTER (CHOKE)

AUTOMATIC SIDE STARTER INSPECTION

- Remove the fuel hose from the carburetor.
- Loosen the carburetor float chamber drain screw, and drain the fuel in the carburetor.
- Remove the automatic side starter lead wire, and remove the wore clip.
- Remove the carburetor clamp, and remove the carburetor.
- Check the connection between the two lead wires.
- The voltage should be below 10V. If it exceeds the specific value, it should be replaced.

3-24 ENGINE AND TRANSMISSION

- While the engine is cold, link a hose on the reserve supply fuel line and blow very gently to see if it is obstructed and if the auto side starter is not good. Replace if necessary
- Remove the auto side starter cover.
- Remove its positioning bolts and pieces.
- Remove the auto side starter.
- Inspect the auto side starting valve and fuel injection needle for wear.
- Inspect the O-ring wear.

FLOAT CHAMBER

FLOAT CHAMBER REMOVAL

- Remove the carburetor. (See Section 30, CARBURETOR REMOVAL)
- Remove the clamp, and remove the float chamber.
- Remove the O-ring, and turn out the float chamber screw. Remove the float pin, float, and float valve.
- Remove the choke adjusting screw and air adjusting screw.

Before removing, tighten the two screws, gently, counting the number of turns, then remove the screws.

Do not use too much force, or it will damage the air adjusting screw head surface.

- Remove the main fuel injection nozzle and fuel injection needle seat.

FLOAT CHAMBER INSPECTION

Inspect the float for any damage and for no fuel in the float. Inspect the float valve and float valve seat for wear. If there is wear, it should be replaced.

Clear every fuel line and air line on the carburetor body with compressed air.

FLOAT CHAMBER INSTALLATION

- Install the main fuel injection nozzle and fuel injection needle seat.
- Install the air adjusting screw and choke adjusting screw, and turn them into the proper position according to the noted number of turns while removing.
- Mount the float valve, the float, and the float pin.
- Tighten the float pin positioning screw.
- Replace the carburetor. (See CARBURETOR INSTALLATION)

FUEL LEVEL INSPECTION

Measure the fuel level height.

Fuel level height	18.5mm
-------------------	--------

Inspect the float for any damage and inspect the float valve for excess wear.

Confirm the up and down movement of the float is normal.

3-25 ENGINE AND TRANSMISSION

AIR CHECK VALVE (ACV)

The air check valve can avoid some abnormality when the throttle closes too quickly, such as that the mixed gases are too thin.

The structure of the air check valve is shown in the picture.

The air check valve starts working under 50 km/h, and impels the second air inlet to burn, and reduce CO displacement.

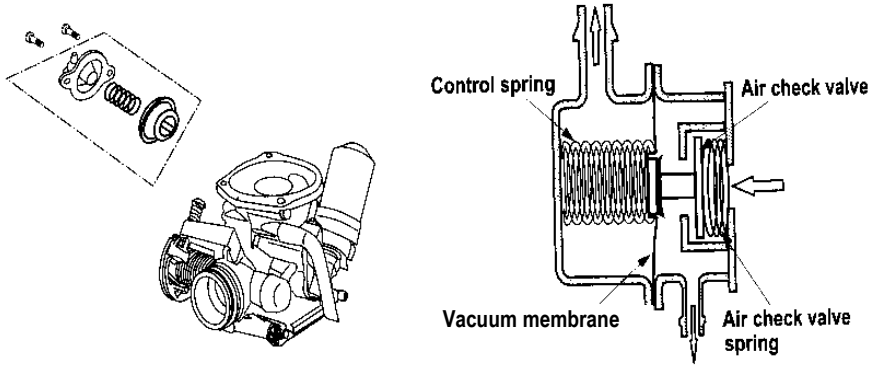

AIR CHECK VALVE REMOVAL

- Remove the air inlet manifold of the cut valve.
- Remove the bolt, and remove the vacuum membrane cover, the spring, and the vacuum membrane.

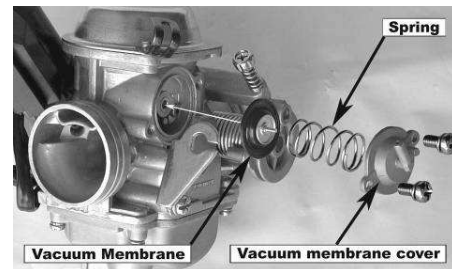

AIR CHECK VALVE INSTALLATION

- Mount the vacuum membrane on the carburetor.
- Mount the spring, the vacuum membrane cover, and the lock bolt.

The bottom side of the vacuum membrane should be aligned with the carburetor and the top side should be aligned with vacuum membrane.

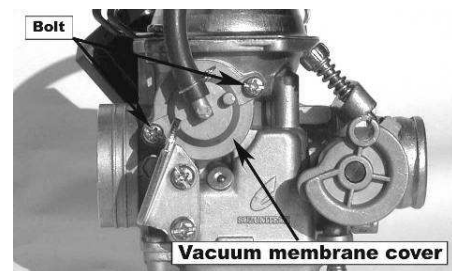

When installing, make sure every connecting pipe is connected properly, and cannot be pinched, bent, or clogged up.

3-26 ENGINE AND TRANSMISSION

STARTING MECHANISM INSPECTION AND SERVICING

STARTER MOTOR

THE STARTER MOTOR IS A DIRECT CURRENT (DC) MOTOR, AND ITS STRUCTURE IS SHOWN IN THE PICTURE.

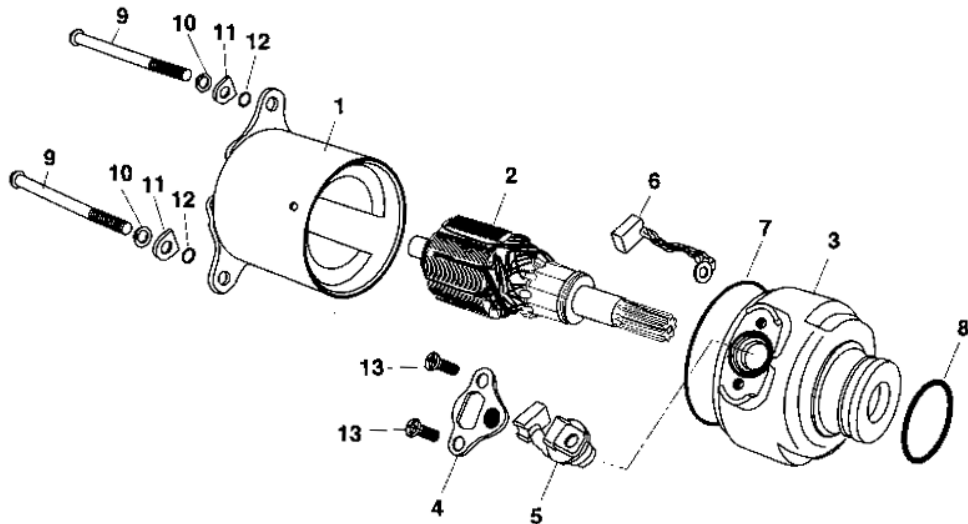

- | | | |
|------------------------------|-------------------------------------|-------------------|
| 1. Outer Cover, Motor | 5. Carbon Brush, Positive Electrode | 8. O-ring |
| 2. Rotor, Motor | | 9. Bolt |
| 3. Base, Carbon Brush | 6. Carbon Brush, Negative Electrode | 10. Spring Washer |
| 4. Plate, Positive Electrode | | 11. Washer |
| | 7. O-ring | 12. O-ring |

STARTER MOTOR REMOVAL

Before removing, disconnect the negative battery terminal. Then, attempt to start the engine by turning the key switch. At this time the starter motor should not run. This must be done to ensure safety.

- Remove the starter motor lead wire clamp.
- Remove the starter motor holding bolt, and remove the starter motor

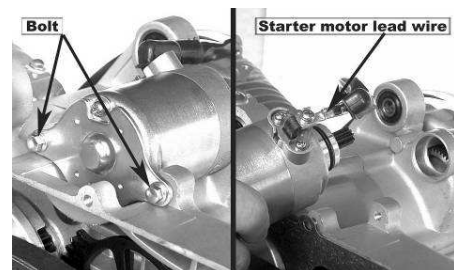

3-27 ENGINE AND TRANSMISSION

- Roll up the rubber water- resistance cover, and remove the starter motor joint.
- Remove the motor case bolt, the carbon brush seat, and the motor case etc.

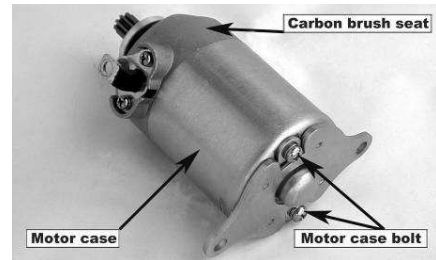

ARMATURE INSPECTION

Inspect the armature surface for uneven wear or damage or burn (changing color).

When there are metal shavings attached to the gap of the armature surface, use a cleaning cloth to remove them.

Please do not use sandpaper to grind. Also do not wash it in any solvent which can dissolve or damage its insulation.

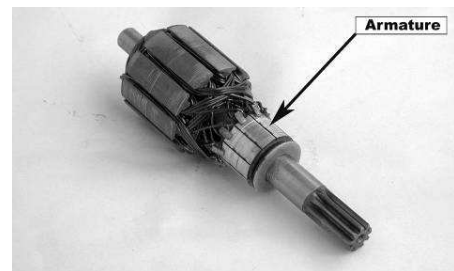

Measure the conducting condition of the armature coil according to the picture. It should be conductive.

Measure the conducting condition between the armature coil and the armature according to the right picture. It should be non-conductive. If not, it should be replaced.

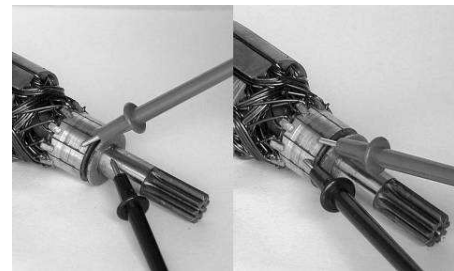

CARBON BRUSH INSPECTION

Inspect the insulating condition between the connecting wire terminal and the starter motor case. It should be nonconductive.

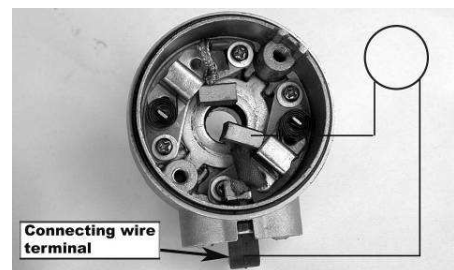

Inspect the conducting condition between the connecting wire terminal and the carbon brush. It should be conductive. Measure the length of the carbon brush. Replace it if it exceeds service limit.

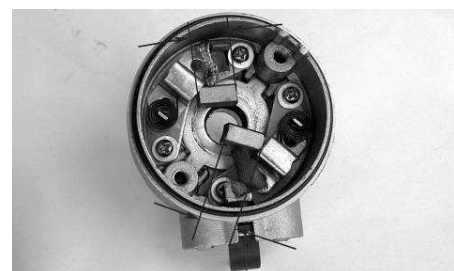

3-28 ENGINE AND TRANSMISSION

Measure the insulating condition of the carbon brush bracket. It should be non-conductive. If not, it should be replaced.

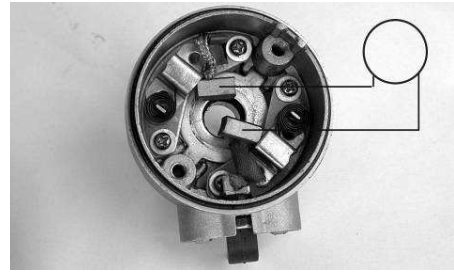

Inspect the needle bearing in the carbon brush base. It should be able to move smoothly with no play.

Inspect the dust seal for wear or damage.

If so, it should be replaced.

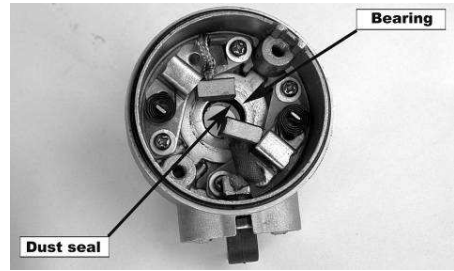

STARTER MOTOR INSTALLATION

- Apply some oil on the dust seal.
- Install the carbon brush on the carbon brush base.
- Apply a little oil on the moving part of the armature ends.
- Put the carbon brush into the bracket, and then install the carbon brush base.

Do not damage the contact area of the carbon brush and the armature.

While installing, do not damage the lip of the dust seal.

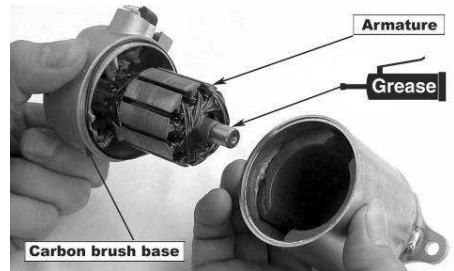

- Mount the new O-ring on the carbon brush base.
- Install armature into starter motor case, making sure to not damage the carbon brushes.
- Tighten motor case bolts.

Make sure the starter motor case is free of metal particles, because it is magnetic.

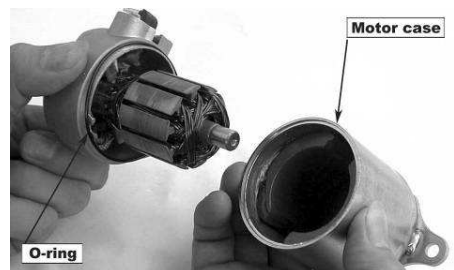

Before installing the starter motor on the vehicle after assembling it, first connect the lead wires and inspect if the motor runs normally.

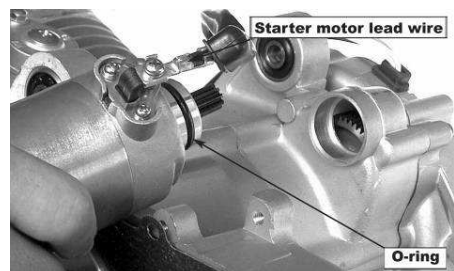

- Apply oil on the O-ring, and install the starter motor.
- Tighten holding bolts.

3-29 ENGINE AND TRANSMISSION

REDUCTION MECHANISM

The picture shows the structure of the reduction mechanism.

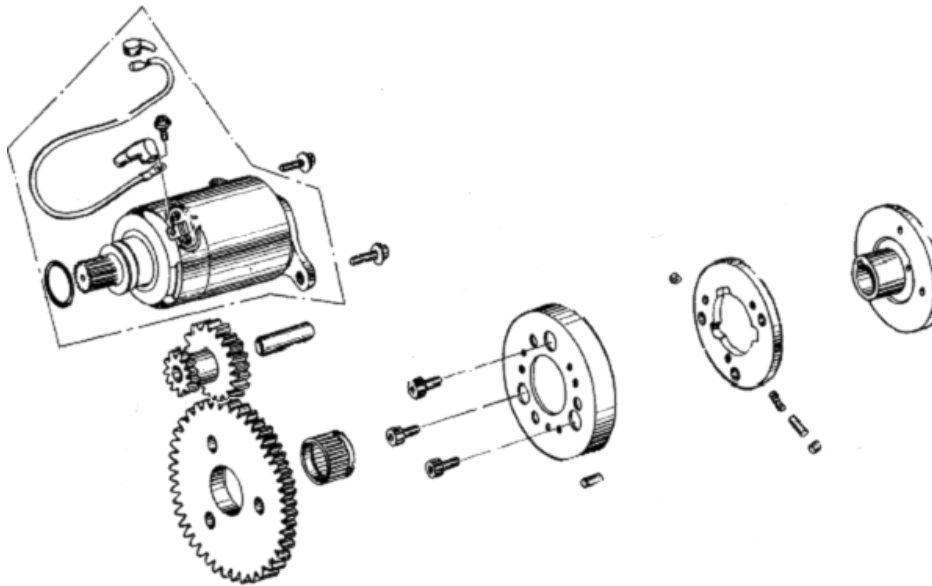

REDUCTION GEAR INSPECTION

Remove the starting clutch.

Remove the reduction gear to inspect its wearing degree.

Measure the inner diameter of the reduction gear shaft. It should be replaced when the diameter is more than 10.05mm.

Measure the outer diameter of the reduction gear shaft. It should be replaced when the diameter is less than 9.94mm.

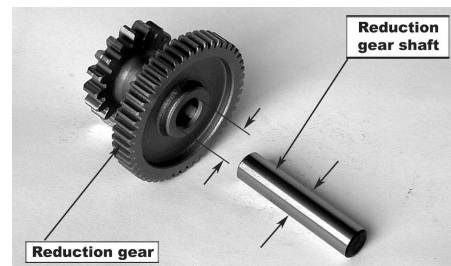

STARTING CLUTCH REMOVAL

Remove the right crankcase cover.

Remove the left crankcase cover.

Hold the drive face with the universal set wrench.



Remove the starting clutch fixing nut.

Notice that the thread of the fixing nut should be left-handed rotation.

Remove the starting clutch (the whole set).

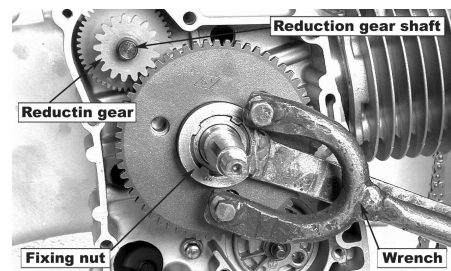

3-30 ENGINE AND TRANSMISSION

STARTING CLUTCH INSPECTION

Inspect the movement between the clutch and the driving gear for normality. The driving gear should smoothly turn clockwise and should not move counterclockwise.

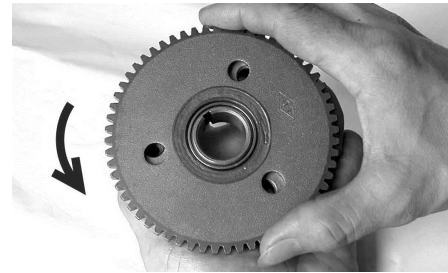

Inspect if there is any abrasion or damage on the contact surface between the driving gear and the needle bearing. It should be replaced if the surface is damaged.

Measure the inner diameter of the driving gear. It should be replaced when the diameter is more than 32.06mm.

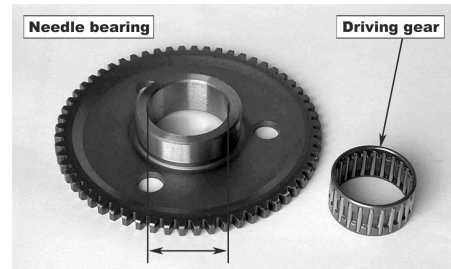

Inspect the condition of the needle bearing. It should be replaced if there is any damage.

Inspect if there is any abrasion or damage on the contact surface between the outer clutch component and the roller.

Inspect if there is any damage to the roller.

Inspect if there is any distortion of the spring.

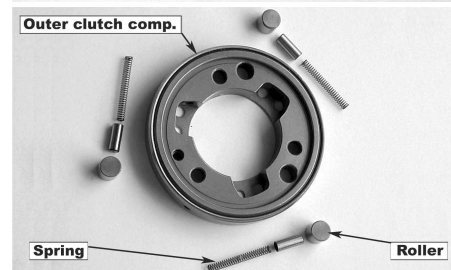

If the damage is severe, it should be replaced.

Measure the inner diameter of the flange clutch. It should be replaced when the diameter is more than 27.94mm.

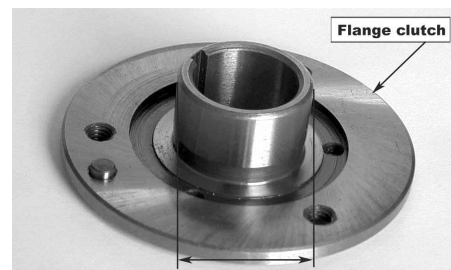

STARTING CLUTCH INSTALLATION.

- Install the spring, the roller, and the top pin on the body of the clutch.
- Align the dowel pin on the flange clutch with the hole on the clutch body, the install.
- Apply some thread lock on the outer clutch component bolt and tighten.
- Apply some oil on the needle bearing and the driving gear, and then put the outer clutch component on.

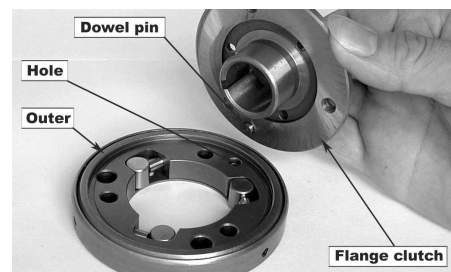

3-31 ENGINE AND TRANSMISSION

- Align the groove of the woodruff key on the crank, and install the starting clutch.
- Apply some oil on the reduction gear and the reduction gear shaft, then install.
- Hold the drive face with the universal wrench, at the same time fastens the clutch nut.

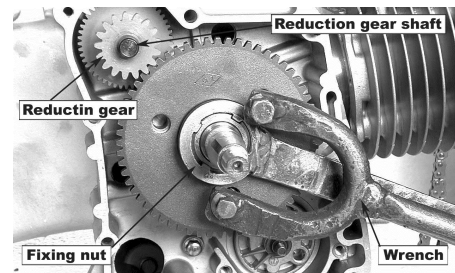

Notice that the thread of the nut should be left-handed rotation.

- Install the right crankcase cover.
- Install the left crankcase cover.

Note:

The reduction mechanism and the engaging mechanism as a whole unit is called the starter.

STARTER RELAY INSPECTION

Attempt to start the engine with the key switch and listen if there is a “click” sound. If there is, it is normal. If there isn't, follow the below procedures to inspect.

Inspect to see if the brake switch is conductive. At this time, turn the main switch ON and hold the brake lever.

The battery voltage should be at 12 volts.

Measure the voltage between the inlet line (the green/yellow wire), starting relay, and the ground wire of the body. The voltmeter reading should be close to the magnitude of voltage between the two ends of the battery. If not, then the brake switch, wire or the wire connector is bad.

Inspect if the key switch is conductive; remove the starting relay inlet line (the green/yellow wire).

Connect the yellow/red wire with the ground wire, and turn the key switch to START. It should be conductive between the yellow/red wire and the ground wire, or the key switch, its wire, or the wire connector is not good. Inspect if the working condition of the starting relay. At this time, remove the starting relay. Connect the C and D end of the starting relay with the battery, and the A and B end with the multimeter.

The battery voltage should be at 12 volts.

At this time the multimeter should indicate a conductive condition, or the starting relay is not good.

3-32 ENGINE AND TRANSMISSION

BELT DRIVEN CVT MECHANISM INSPECTION AND SERVICING

GENERAL INTRODUCTION

The belt driven CVT mechanism is made up of two belt pulleys (the drive belt pulley and the driven belt pulley) whose diameter can be changed, and a notched driven belt. The driving belt pulley is mounted on the engine crankshaft, and the driven belt pulley connects with the rear driven mechanism.

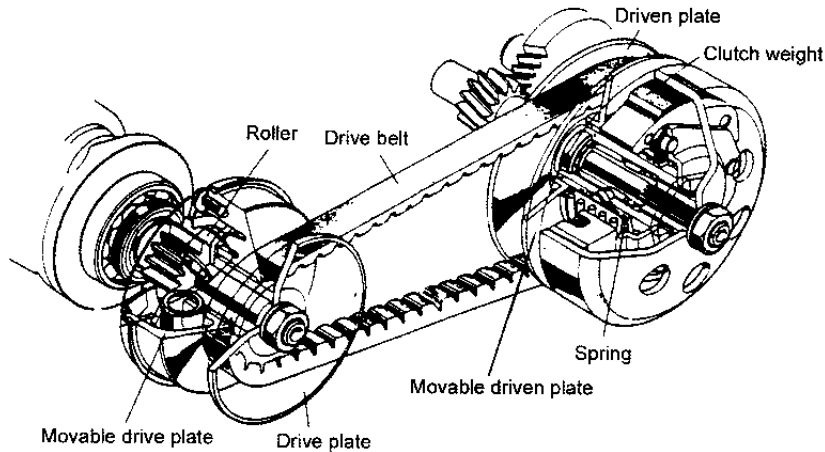

Its basic operational principle is to realize automatic CVT by the diameter changes (the transmission ratio changes) of the driving and driven belt pulley.

When the diameter of the driving belt pulley changes from small to big, proportionally the diameter of the driven belt pulley changes from big to small (because the perimeter of the driven belt is constant), at this time the speed increases. On the contrary, the speed decreases.

The structure of the driving belt pulley is shown in the picture.

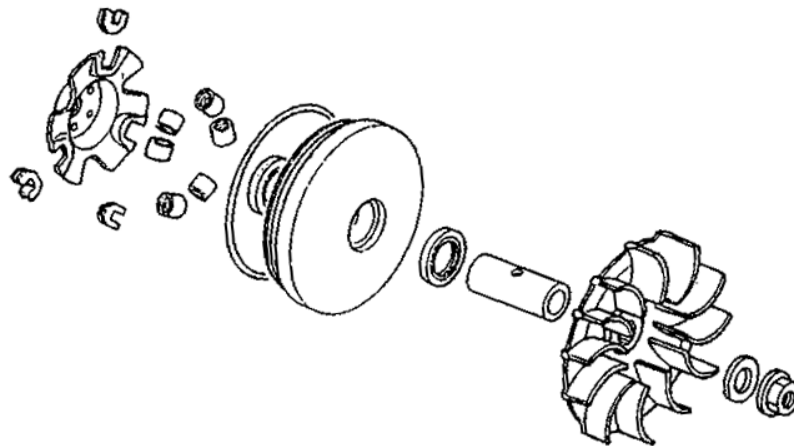
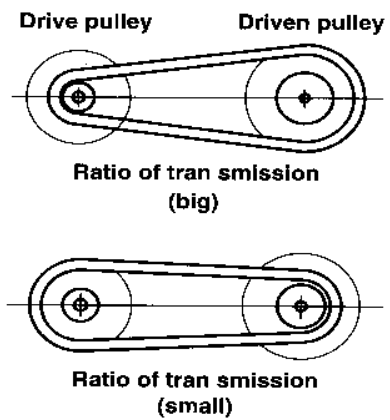

3-33 ENGINE AND TRANSMISSION

The picture shows the working theory of the driving belt pulley.

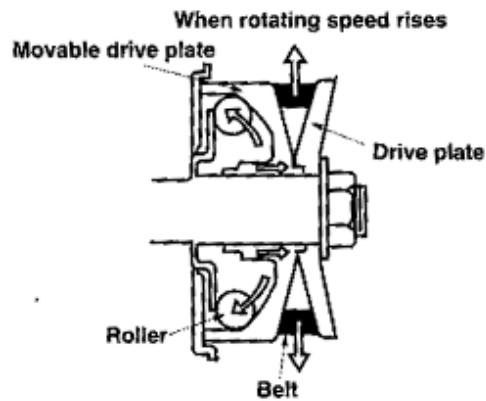

The picture shows the structure of the driven belt pulley. The clutch shown in this picture is the automatic dry centrifugal weight clutch.

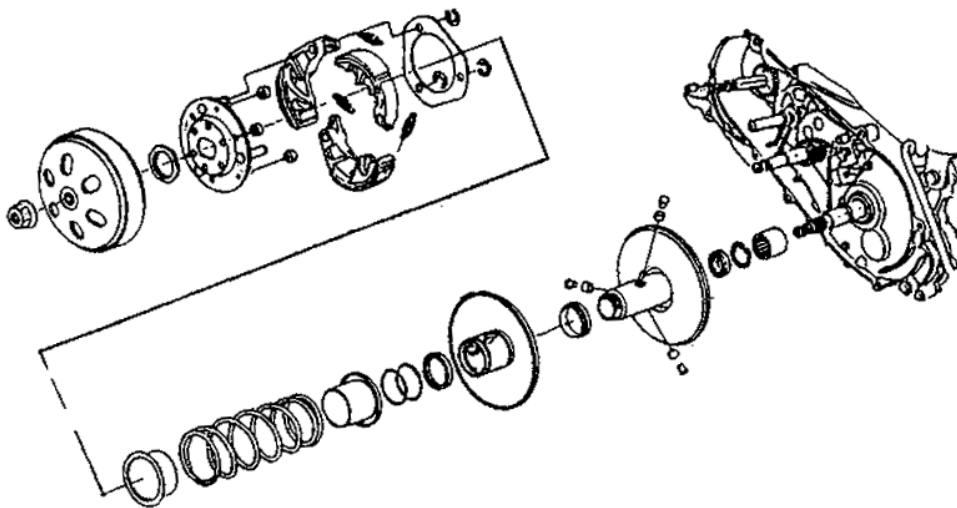

DRIVE BELT PULLEY

DRIVE BELT PULLEY REMOVAL

- Remove the left crankcase air pipe lock bolt.
- Remove the kick starter, and remove the left crankcase fixing bolt. Remove the left crankcase cover. Remove the gasket and the dowel pin.
- Hold the drive plate with a universal wrench, and then remove the nuts and gasket on the drive plate shaft. Remove the drive plate.
- Remove the driven belt from the drive plate.

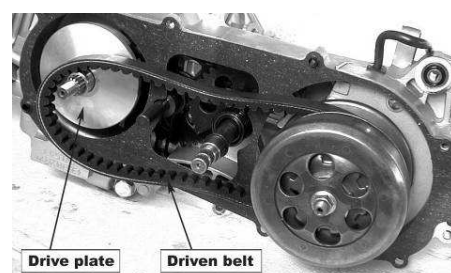
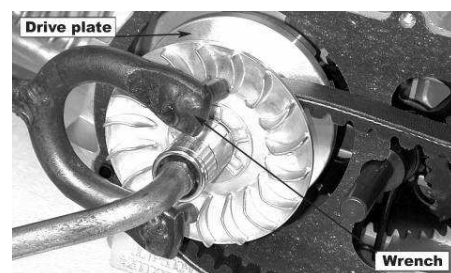

3-34 ENGINE AND TRANSMISSION

- Remove the movable drive plate (the whole set).

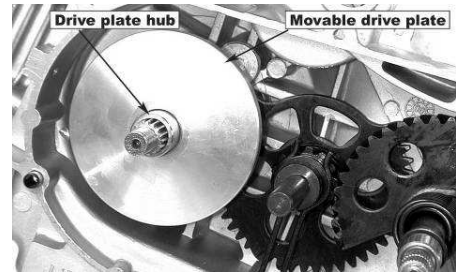

- Remove the ramp plate.

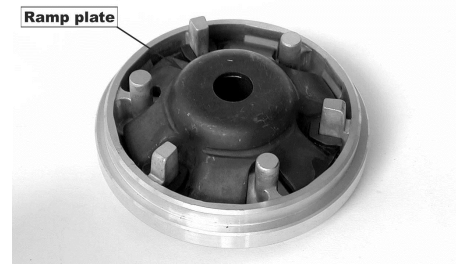

- Remove the centrifugal rollers.



DRIVE BELT PULLEY INSPECTION

Inspect if there is any abrasion or damage of the centrifugal roller.

Measure the outer diameter of the centrifugal roller.

Service limit	17.0mm
---------------	--------

Measure the inner diameter of the movable drive plate.

Service limit	24.06mm
---------------	---------

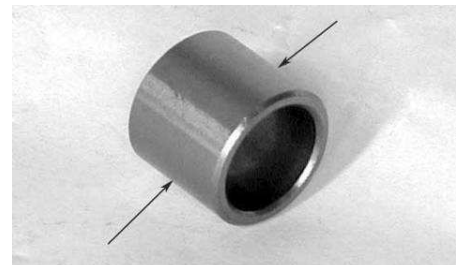

Inspect if there is any abrasion or damage of the drive plate hub.

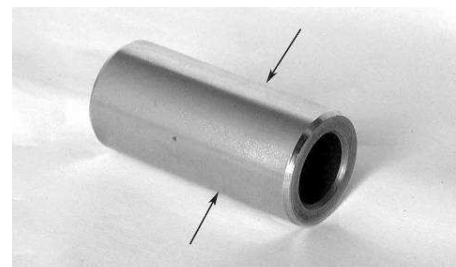

3-35 ENGINE AND TRANSMISSION

Measure the outer diameter of the drive plate hubs movable surface.

Service limit	23.94mm
---------------	---------

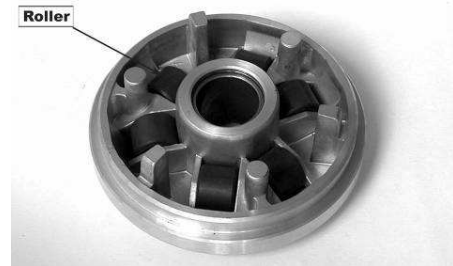

DRIVE BELT PULLEY INSTALLATION

- Apply some grease evenly in the movable drive plate.
- Put the centrifugal rollers into the movable drive plate.
- Install the ramp plate.

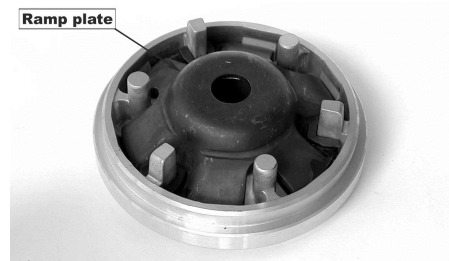

- Put the drive plate hub into the drive plate.



- Install the movable drive plate on the crankshaft.

- Enlarge the driven plate belt groove and mount on the driven belt. Mount the other end of the driven belt on the drive plate hub.

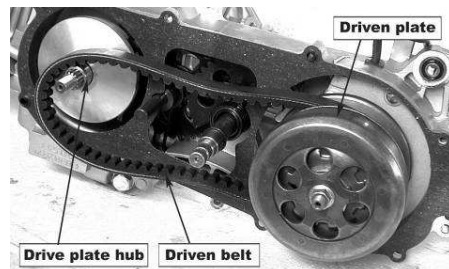

- Mount the drive plate, the drive plate washer, and nut.

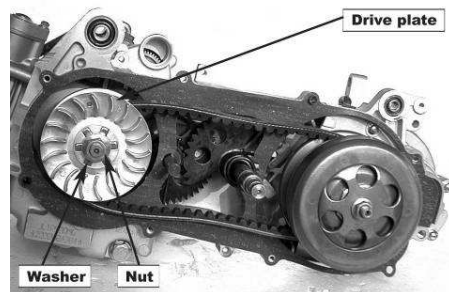

- Hold the drive plate with a multiuse holder to make it unmovable.
- At the same time fasten the nut on the shaft.

Do not allow any grease or oil on the surface of the movable drive plate and the driven belt.

3-36 ENGINE AND TRANSMISSION

CLUTCH

CLUTCH REMOVAL

- Remove the left crankcase cover.
- Remove the drive plate and the driven belt.
- Hold the clutch friction plate with a multiuse holder, and remove the nut.

- Remove the clutch friction plate.

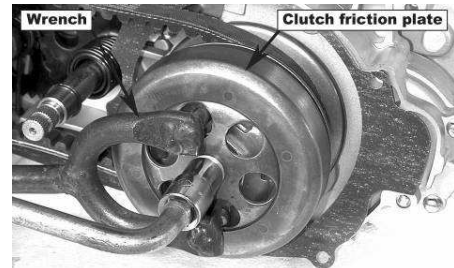

CLUTCH INSPECTION

Inspect if there is any abrasion or damage on the clutch friction plate.

Measure the inner diameter of the clutch friction plate.

Service limit	125.5mm
---------------	---------

Inspect if there is any abrasion or damage of the clutch centrifugal weight friction piece.

Measure the thickness of the clutch centrifugal weight friction piece.

Service limit	1.5mm
---------------	-------

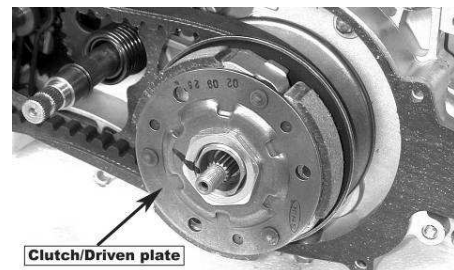

CLUTCH DISASSEMBLY

If it is necessary to replace the centrifugal weight set, then you must disassemble the clutch.

When the friction piece is worn, it should be replaced with the centrifugal weight set.

- Remove the clutch friction plate.
- Remove the whole set of clutch/driven plate.
- Compress the driven pulley spring with the clutch spring compressor, and at the same time remove the nut on the shaft.

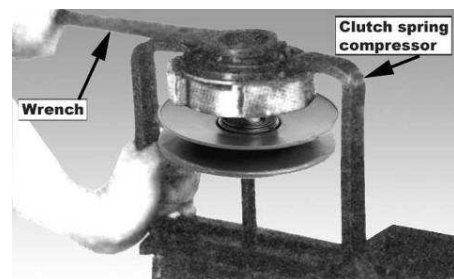

3-37 ENGINE AND TRANSMISSION

- Disassemble the clutch with the driven pulley.

- Remove the circlip, and remove the connecting piece.
- Remove the clutch centrifugal weight set and the spring.

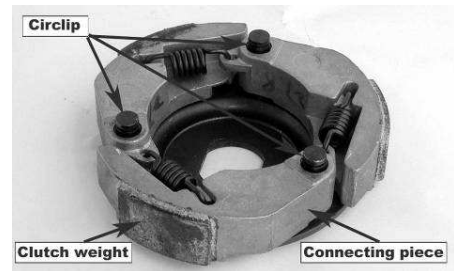

CLUTCH INSTALLATION

- Mount the clutch damper rubber on the drive plate pin.
- Mount the new clutch weight set and spring on the drive plate.
- Install the connecting piece, the circlip, and the bottom plate.
- Finally reverse the removal procedure for installation.

When assembling the clutch and the driven plate, you must use a clutch spring compressor, or it will damage the spring.
No grease on the driven pulley.

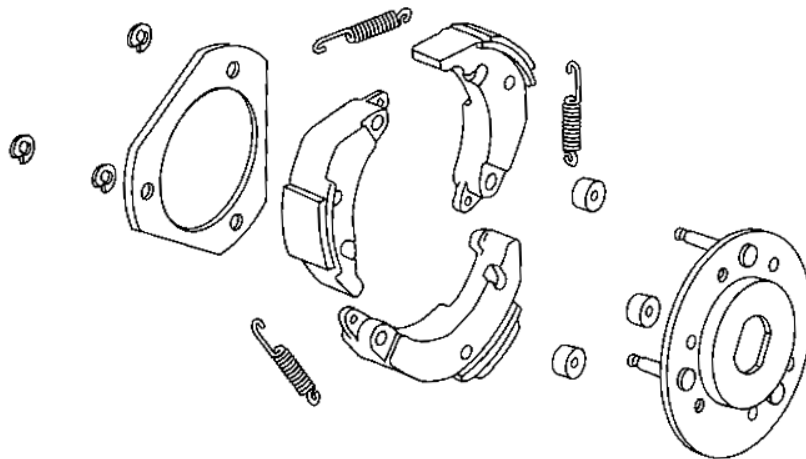

DRIVEN BELT PULLEY

DRIVEN BELT PULLEY REMOVAL

After removing the clutch friction plate, remove the guide pin, the roller and the movable driven plate.

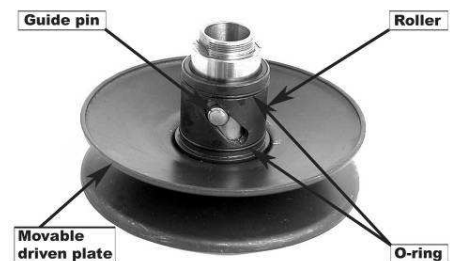

3-38 ENGINE AND TRANSMISSION

Remove the oil seal on the movable driven plate.



DRIVEN BELT PULLEY INSPECTION

Measure the free length of the driven belt pulley spring.

Service limit	163.7mm
---------------	---------

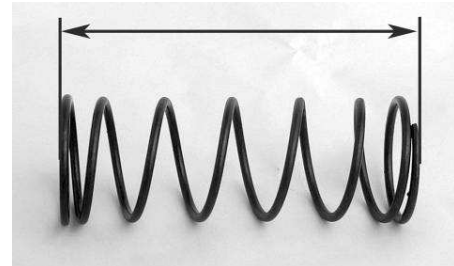

Inspect if there is any abrasion or damage on the driven plate.

Measure the outer diameter of the driven plate pulley hub.

Service limit	33.94mm
---------------	---------

Inspect if there is any abrasion or damage of the movable driven plate.

Service limit	34.06mm
---------------	---------



Inspect if the groove of the guide pin is worn.

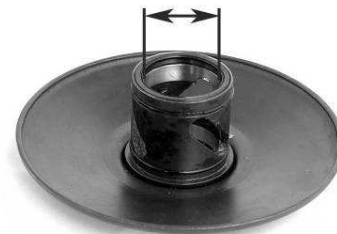

DRIVEN PLATE BEARING REPLACEMENT

If the driven plate needle bearing and the ball bearing are loose, damaged, or have some unusual sound, they should be replaced.

- Remove the needle bearing from the driven plate.

The removed bearing cannot be reused.

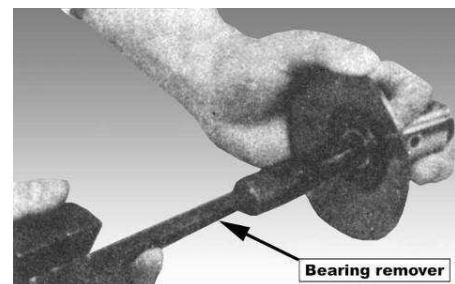

3-39 ENGINE AND TRANSMISSION

- Remove the circlip from the driven plate.
- Drive the ball bearing out.

The removed bearing cannot be reused.

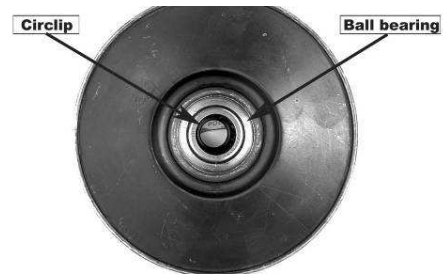

- Apply some grease on the new ball bearing.
- Drive the ball bearing into the driven plate with its front face upwards.
- Mount the circlip.
- Apply grease evenly on the inner wall of the driven plate.

Use the prescribed grease.

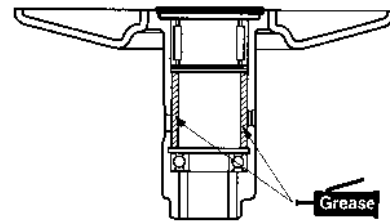

- Drive in the new needle bearing with its mark upwards.

Use the specific tool.

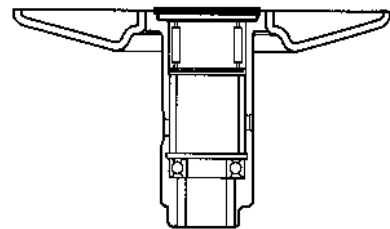

- Apply grease around the bearing.

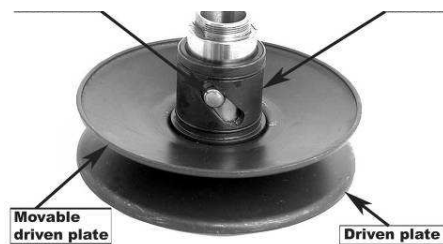

DRIVEN BELT PULLEY INSTALLATION

- Remove the grease on the driven plate.
- Mount the oil seal.
- Apply a little grease on the O-ring.

- Mount the movable driven plate into the driven plate.
- After applying some grease on the roller, the guide pin, mount them into the driven plate hole.
- Install the oil seal collar.
- Remove the excessive grease.

No grease on the movable faces of the driven plate.

- Assemble with the clutch and install on the left crankcase.

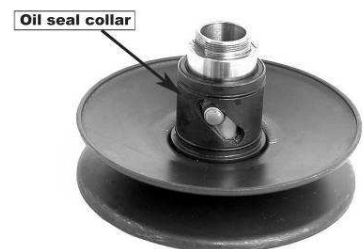

3-40 ENGINE AND TRANSMISSION

TRANSMISSION BELT

TRANSMISSION BELT INSPECTION

Remove the left crankcase cover.

Inspect if the transmission belt is chapped or worn.

Measure the width of the belt.

Service limit	19.0mm
---------------	--------

Replace the belt if its width is less than the above limitation.

When replacing, you must use the OEM part for correct fit.

See the drive pulley removal and installation procedure for the replacement.

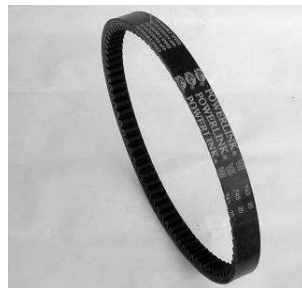
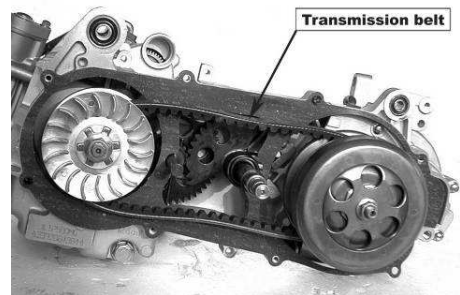

TRANSMISSION

The picture shows an overview of the transmission.

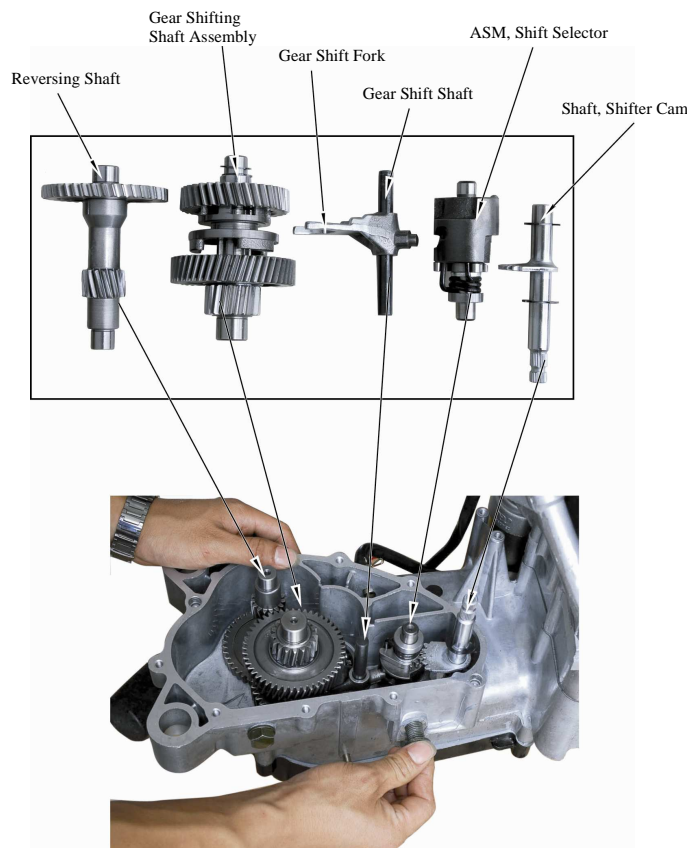

3-41 ENGINE AND TRANSMISSION

TRANSMISSION ASSEMBLY

- Put the reversing shaft into the hole of bearing 6203 in the left cover, fit the adjusting washer 15 on the gear shifting shaft assy. and put them into the hole of bearing 6202.

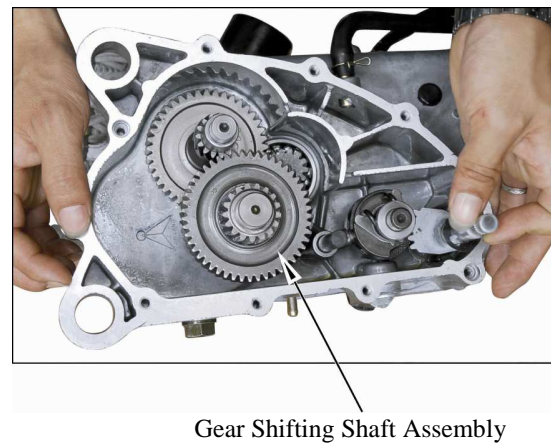
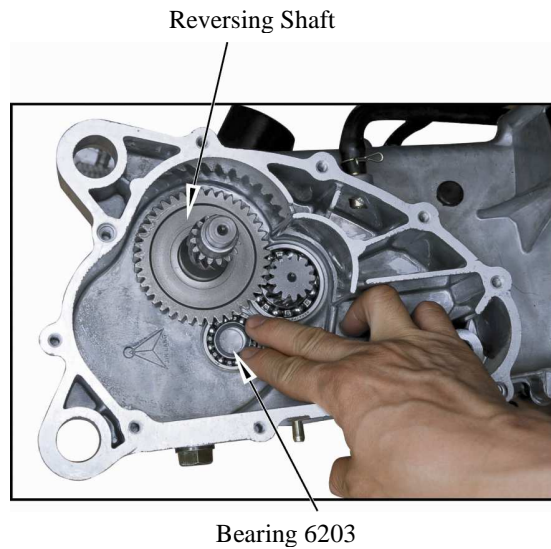



GEAR SHIFTING SHAFT ASSY.

Assemble these parts according to the picture on the right, in the order shown.



3-43 ENGINE AND TRANSMISSION

- Put the gear shift fork sets into the gear shifting shaft assy., and then use gear shift shaft to fit the gear shift fork in the right position. Assemble the shift selector assy., and fit one end of gear shift fork into the shift selector assy. at the same time.

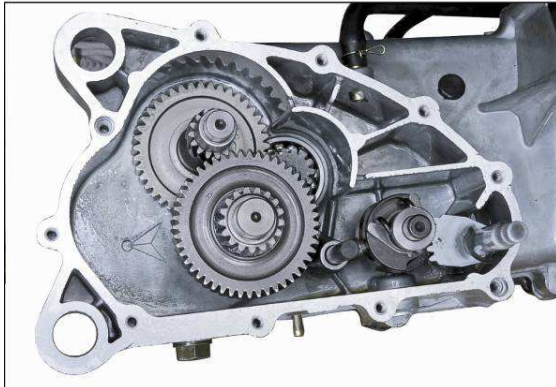
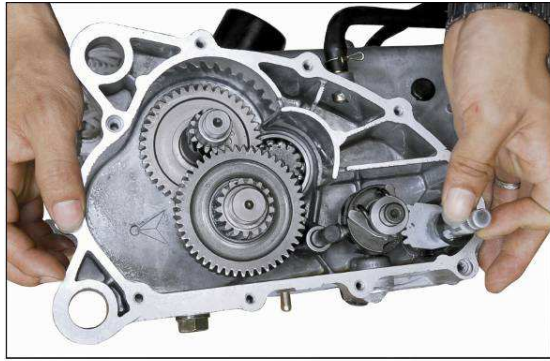

- Revolve the shift selector in proper to ensure that the mark on shift camshaft set in the middle of 2 marks on the shift selector exactly. That is the assembling of shift camshaft assy.

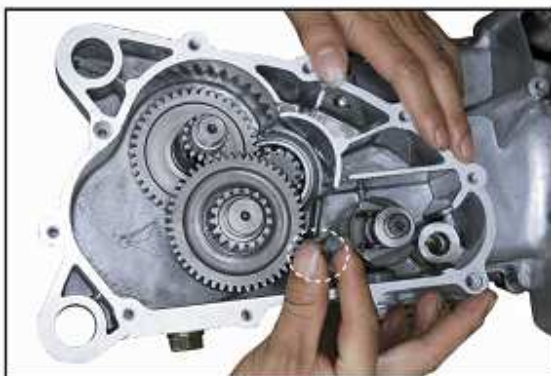

3-44 ENGINE AND TRANSMISSION

- Fit the shift shaft's locating spring and small steel ball $\varnothing 9.5$ into the shift shaft's locating bolt, and locking the bolt with the washer.
- Use the special tool to turn the shift camshaft to ensure each shift can turn the shaft freely.

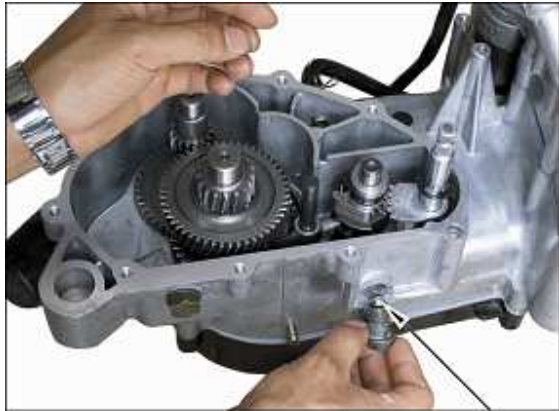

Small steel ball $\varnothing 9.5$



Locating Spring

Locating Bolt



3-45 ENGINE AND TRANSMISSION

- Clip the circlip with caliper as in the picture on the right. Put the circlip into the groove of shaft to prevent the lateral movement of bearing

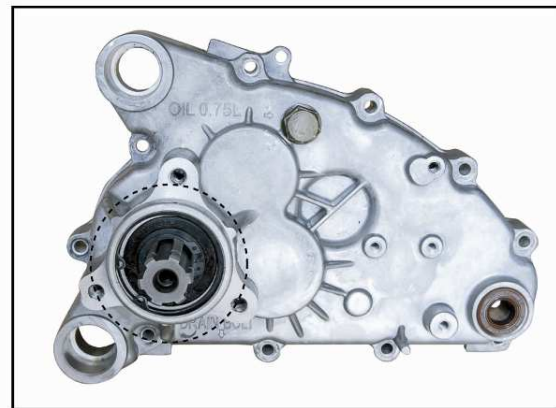
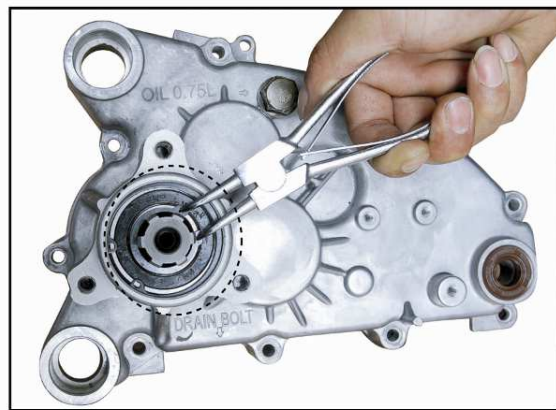
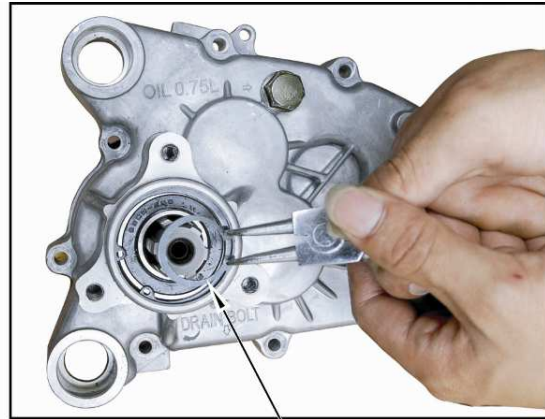

3-46 ENGINE AND TRANSMISSION

OIL SYSTEM INSPECTION AND SERVICING (W/ OIL FILTER)

Check all lines for leaks and cracks.

To replace an oil line, first make sure the engine is cool and that the oil is not hot. Loosen the bolt on both ends of the hose. Then, take the hose out and replace with a new one. Retighten bolts.

OIL FILTER REPLACEMENT

The oil filter is removed by turning clockwise, using an oil filter wrench. Before installing the new filter, fill it with oil 2 mm from the top and replace back on the oil cooler turning counterclockwise. The engine manufacturer suggests that you change your oil and filter after 40hr of running.

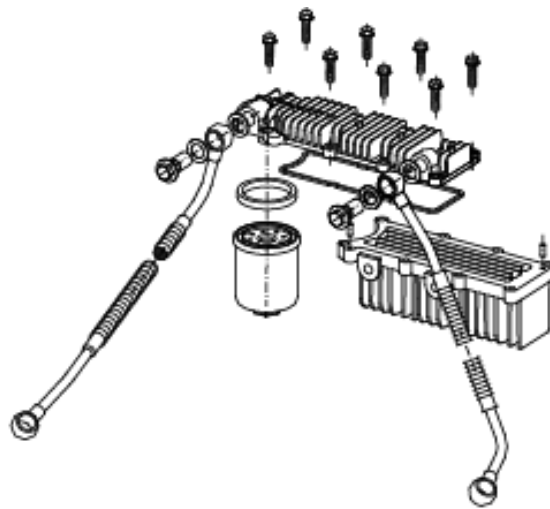

4 ELECTRICAL SYSTEM

CONTENTS

4-1	ELECTRICAL SYSTEM	65
	CHARGING SYSTEM INSPECTION AND SERVICING	65
	Electrical Drain Testing	65
	CHARGING STATUS INSPECTION	65
	BATTERY	65
	BATTERY REMOVAL	65
4-2	ELECTRICAL SYSTEM	66
	BATTERY INSTALLATION	66
	BATTERY OPEN-CIRCUIT VOLTAGE INSPECTION	66
	BATTERY CHARGING	66
4-3	ELECTRICAL SYSTEM	67
	PRIMARY COIL	67
	PRIMARY COIL INSPECTION	67
4-4	ELECTRICAL SYSTEM	68
	GENERATOR REMOVAL AND INSPECTION	68
	GENERATOR REMOVAL	68
4-5	ELECTRICAL SYSTEM	69
	GENERATOR INSTALLATION	69
	REGULATOR RECTIFIER	69
	MAIN WIRING – SUB ELECTRIC CIRCUIT INSPECTION	69
4-6	ELECTRICAL SYSTEM	70
	REGULATOR RECTIFIER INSPECTION	70
	RESISTOR RESISTANCE VALUE MEASUREMENT	70
	IGNITION SYSTEM	70
	IGNITION TIMING INSPECTION	70
4-7	ELECTRICAL SYSTEM	71
	IGNITION SYSTEM INSPECTION	71
4-8	ELECTRICAL SYSTEM	72
	IGNITION CHARGING COIL INSPECTION	72
	TRIGGER WINDING INSPECTION	72
	CDI COMPONENT INSPECTION	72
4-9	ELECTRICAL SYSTEM	73
	IGNITION COIL REMOVAL	73
	IGNITION COIL INSTALLATION	73
	PRIMARY IGNITION COIL INSPECTION	73
	SECONDARY IGNITION COIL INSPECTION	73
	SPARK PLUG INSPECTION	73
4-10	ELECTRICAL SYSTEM	74
	WIRING SCHEMATIC	74

4-1 ELECTRICAL SYSTEM

CHARGING SYSTEM INSPECTION AND SERVICING

ELECTRICAL DRAIN TESTING

Turn the main switch on the “OFF” position.

Disconnect the negative ground wire from the battery.

Connect the positive end of the ammeter with the negative end of the battery.

Connect the negative end of the ammeter with the ground wire.

Test the electric leakage. In general, it demands the number should be less than 1 m A; if it is unusual, inspect if there is short circuit of the main switch and the main wiring.

CHARGING STATUS INSPECTION

Install a fully charged battery.

Connect the voltmeter between the binding posts of the battery.

Remove the fuse, and connect the ammeter between the two ends of the fuse holder.

Connect the tachometer with the engine (it's not needed when there is rpm indicator on the vehicle).

CAUTION

Ensure the vehicle's rear wheels are off the ground.
--

Start the engine, and accelerate slowly, measure the charging voltage and current.

Charging voltage (V)	13.5 ~ 15.5 (Typically 15V at idle)
Charging current (A)	0.5

*Measuring condition: 5000 rpm

If the voltage is not in the range of the above specified value, please inspect the voltage regulator.

BATTERY

The battery used on the vehicle is a maintenance-free battery. For long periods of storage, the battery will discharge by itself, so it should be charged every 3 months. After 2 ~3 years of regular usage, the capacity of the battery will descend, so it may need charging between uses. Replace, when necessary with the same type of battery.

BATTERY REMOVAL

Shut down the main switch to make sure no electric current goes through the vehicle.
--

- Disconnect the negative battery lead wire first.
- Disconnect the positive battery second.

The disconnecting order should not be reversed.

When disconnecting the positive cable, do not touch the body of the vehicle with the removal tool, or a short circuit may occur. This can cause damage and may be harmful.
--

4-2 ELECTRICAL SYSTEM

BATTERY INSTALLATION

- Connect the positive cable first, and then connect the negative cable.

BATTERY OPEN-CIRCUIT VOLTAGE INSPECTION

Disconnect the cable on the battery terminals.

Disconnect the negative pole first, then the positive pole.

Measure the voltage between the two poles of the battery.

Strong Battery (Fully charged)	13.1V
Weak Battery (Under charged)	12.3V

Refer to section 4-1 CHARGING SYSTEM INSPECTION AND SERVICING for electrical system testing procedure. Fully charged, a disconnected battery should never fall below 12.8V. This condition indicates a failing battery. The battery may still have enough power to start the engine, but will need to be replaced very soon. Note: results will vary based on ambient temperature. Colder temperatures negatively affect battery potential.

BATTERY CHARGING

Connect the positive pole of the charger with the positive pole of the battery.

Connect the negative pole of the charger with the negative pole of the battery.

Charge the battery for the charging time marked on the battery.

Unless completely necessary, do not use fast charging. Fast charging reduces the life of the battery. No smoking or open fire near the battery when charging. At the beginning or the end of charging, turn off the charger first, in order to avoid the connecting part arcing.
--

Measure the voltage 30 minutes after charging is finished, and it should reach the specified value, or it needs to be recharged.

Charging current	Normal	0.7 A
	Fast	3.0 A
Charging time	Normal	5 ~ 10 hours
	Fast	30 minutes
Charging result	Open - circuit voltage \geq 12.8V	

4-3 ELECTRICAL SYSTEM

PRIMARY COIL

The picture shows the structure of a common generator.

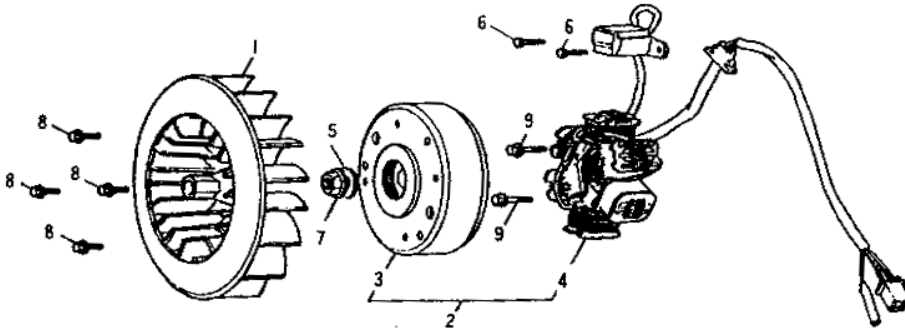

- | | | |
|-----------------------|----------------|---------|
| 1. Cooling Fan | 4. Stator comp | 7. Nut |
| 2. Generator assembly | 5. Washer | 8. Bolt |
| 3. Flywheel comp | 6. Bolt | 9. Bolt |

PRIMARY COIL INSPECTION

The inspection work can be done on the engine, and there is no need to remove the generator.

Remove the 4- core connector of the generator.

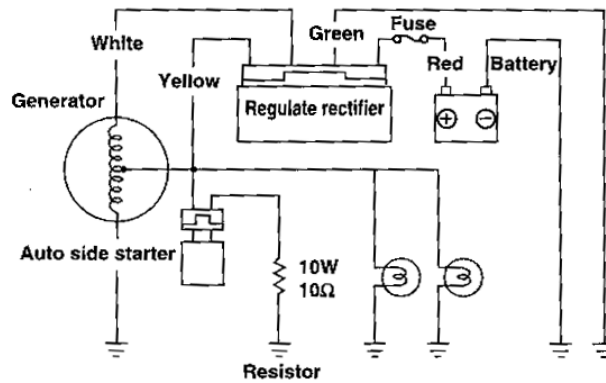

Measure the resistance value between the white wires of the generator and connecting wire of the vehicle body.

Standard value	0.2 ~ 0.4 Ω (20°C)
----------------	--------------------

When the actual value is more than the standard value, the coil should be replaced.

4-4 ELECTRICAL SYSTEM

GENERATOR REMOVAL AND INSPECTION

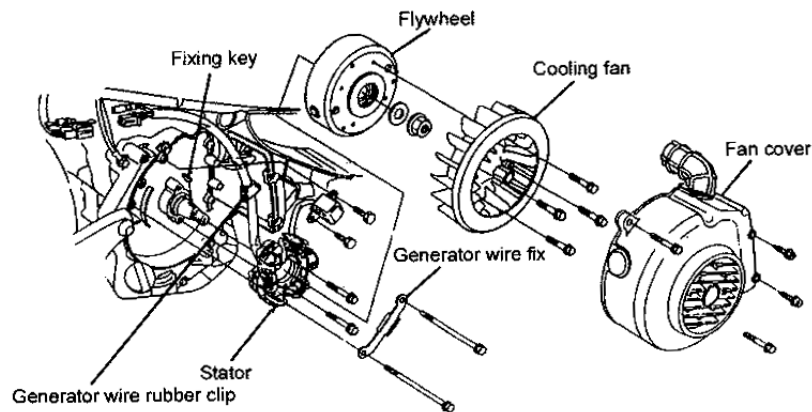

GENERATOR REMOVAL

- Remove the cooling fan cover bolt and screw.
- Remove the cooling fan cover.
- Remove the cooling fan bolt, and remove the cooling fan.
- Hold the flywheel with a universal holding wrench, at the same time remove the flywheel nut.
- Remove the flywheel with a flywheel puller, and remove the solid key.
- Remove the generator wire connector.
- Remove the generator wire holder.
- Remove the generator coil bolt.
- Remove the generator wire rubber bushing from the right crankcase.

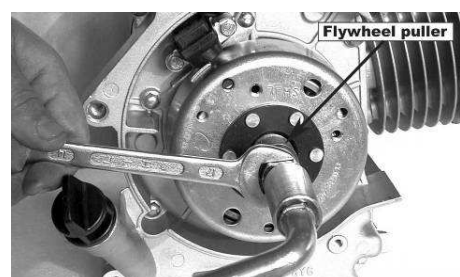
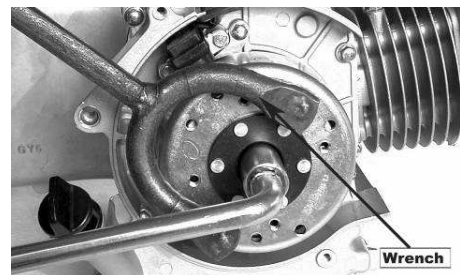

4-5 ELECTRICAL SYSTEM

- Remove the coil set.

Do not damage the coil when removing.

GENERATOR INSTALLATION

Reverse the removal procedure for installation.

When installing the flywheel, make sure there are no metal pieces, such as bolts or nuts, attaching to the inner wall of the flywheel.

After the installation is finished, start the engine to inspect and adjust the ignition timing.

REGULATOR RECTIFIER

MAIN WIRING – SUB ELECTRIC CIRCUIT INSPECTION

Take the voltage regulator rectifier inspection procedure by two step:
First inspect the main wiring – sub electric condition, and then inspect the voltage regulator.
Inspect only when engine is cold.

Remove the 4-core connector of the regulator rectifier.

Measure the conducting status between the main wiring terminals according to the previous wiring diagram.

Connecting type	Normal condition
Battery (the red wire) – Vehicle body	Battery voltage value
Connecting wire (the green wire) – Vehicle body	Conductive
Lighting wire (the yellow wire) – Vehicle body (remove the resistor, side auto starter plug, and turn the lighting switch to OFF)	Generally is 0.1 ~0.8 Ω
Charging wire (the white wire)- Vehicle body	Generally is 0.2 ~ 2.0 Ω

	W (White)	Y (Yellow)	R (Red)	G (Green)
W (White)		∞	3 ~ 100K Ω	∞
Y (Yellow)	∞		∞	5 ~ 100K Ω
R (Red)	∞	∞		∞
G (Green)	∞	5 ~ 100K Ω	∞	

4-6 ELECTRICAL SYSTEM

REGULATOR RECTIFIER INSPECTION

When the main wiring – sub electric circuit condition is normal, inspect the regulator rectifier.

Inspect if the regulator rectifier plug contacts well.

Measure the resistance value between every regulator rectifier terminal.

If the resistance value between the terminals is unusual, replace the regulator rectifier.

RESISTOR RESISTANCE VALUE MEASUREMENT

Measure the resistance value between the resistor wire and the vehicle body. If the actual value is in the range of $\pm 1 \Omega$ of the value marked on the diagram or the resistor, it is normal. If not, it should be replaced.

IGNITION SYSTEM

The circuit working principle is shown in the picture.

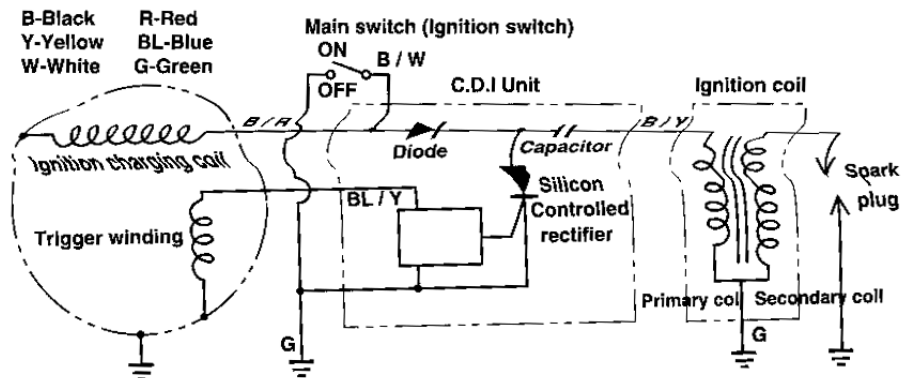

IGNITION TIMING INSPECTION

The CDI ignition system has already been adjusted in the factory, so there is no need to readjust it. If inspecting ignition function is necessary, take the following steps to inspect ignition timing.

Remove the ignition timing hole cover (or remove the fan cover).

Rotate the generator rotor, and align the “F” mark on the rotor with the crankcase timing ignition mark.

Clip the ignition timing indicator light wire clip on the high voltage end of the ignition coil.

Start the engine and let it run at idle. At this time, observe if the mark on the crankcase aligns with the “F” mark on the rotor. If there difference is between $\pm 3^\circ$ it indicates correct ignition timing; on the contrary, if it is greater than $\pm 3^\circ$, timing should be adjusted.

Slowly increase the engine speed to 5000rpm. At this time, if the mark on the crankcase aligns with the rotor ignition advance angle mark, the advance angle device is good; if not, it should be adjusted or replaced.

When adjusting, the trigger winding can be loosened to adjust the angle between it and the ignition charging coil to adjust the ignition time.

4-7 ELECTRICAL SYSTEM

IGNITION SYSTEM INSPECTION

When the spark plug does not spark, first inspect the wires, and if the connections are loose, or contacts are bad, etc. You can follow the electric circuit and take the method of measuring the voltage of every point to find out the trouble. Please refer to the previous picture for the following inspection.

Remove the old spark plug, and install a new one, if plug is bad.

It is important that every electric circuit wire connects correctly.
It is important that the cylinder compression pressure is normal.

Remove the 4-core and 2-core of the CDI component.

Connect the negative end of the multimeter with the positive connecting iron of the primary ignition coil (black / yellow wire).

Turn the ignition key to *START* and read the voltage value on the multimeter, the biggest voltage value should be above 12V. This voltage will drop to 0V when the CDI requests spark. This drop may be so quick that a multimeter may not see the change.

When measuring the voltage, do not touch the metal part of the multimeter with finger, or an electric shock can occur.

Connect the positive end of the multimeter with the ignition charging coil (black/red wire end), and the negative end with a ground wire end (green end). This connection is not required for the CDI, however, this process can still be followed for diagnostic purposes.

Turn the ignition key to *START* and measure the highest voltage of the ignition charging coil, it should be more than 12V.

When the measured highest voltage of the ignition charging coil is not normal, then disconnect the generator connector to make further measurement.

If it is determined that the CDI component end is abnormal, but, the terminal voltage of the generator is normal, then there is a bad wire or bad connection.

When both are not normal, then it is a bad ignition charging coil.

Disconnect the connector of the trigger winding wire (blue/yellow), where it connects to the blue/white wire.

Connect the positive end of the multimeter with the trigger winding (blue/yellow wire terminal) and the negative end with the green wire terminal on the 4-core connector.

Turn the ignition key to *START* and measure the highest voltage of the trigger winding, which should be more than 2.1V.

When the measured highest voltage of the trigger winding is not normal, then remove the generator connector, and make further measurement.

If the measured terminal voltage of the CDI component is not normal, the generator terminal voltage is normal, then there is a bad wire or bad connection.

If both are not normal, then it is a bad trigger winding.

4-8 ELECTRICAL SYSTEM

IGNITION CHARGING COIL INSPECTION

Measure the resistance value between the ignition charging coil (black/red wire) and the body ground wire.

Standard value	300 ~ 1000 Ω (20°C)
----------------	---------------------

When the actual value is more than the standard value, it should be replaced.

TRIGGER WINDING INSPECTION

Disconnect the connector of the trigger winding wire (blue/yellow), where it connects to the blue/white wire.

Measure the resistance value between the trigger winding (blue/yellow wire) and the body ground wire.

When the actual value is more than the standard value, it should be replaced.

Standard value	40 ~ 300 Ω (20°C)
----------------	-------------------

CDI COMPONENT INSPECTION

It is similar with the regular inspection, the CDI component inspection is also divided into two steps:
 First inspect every wiring, winding or coil connected with CDI;
 Then inspect the CDI component.

Remove the CDI component.

Inspect if the connector is loose or eroded.

Inspect the conduction and the resistance value of the main switch, the ignition charging coil, the trigger winding, and the ignition coil. When the main switch is in "OFF" position, it should be conducted, and the resistance value of every coil should be the standard value.

Inspect the resistance value between every CDI component terminal. If the actual value is not in the range of the value in the chart, then the CDI component is faulty.

	SW (B/W)	EXT (B/R)	PC (G/R)	E (G or G/W)	IGN (B/Y)
SW (B/W)		100 ~ ∞	50 ~ ∞	100 ~ ∞	∞
EXT (B/R)	0.5 ~ 50		100 ~ ∞	∞	∞
PC (G/R)	10 ~ 1000	10 ~ 1000		1 ~ 100	∞
E (G or G/W)	0.5 ~ 50	0.5 ~ 50	1 ~ 10		∞
IGN (B/Y)	∞	∞	∞	∞	

B- Black

W- White

R-Red

G-Green

Y- Yellow

The CDI component can also be inspected and measured with the CDI testing instrument.

Please carefully read the instrument specification so as to operate properly.

4-9 ELECTRICAL SYSTEM

Connect CDI component with the special wire of the testing instrument.

Observe the spark condition on the instrument when the switch is turned on different positions (OFF, P, EXT, ON1, ON2)

IGNITION COIL REMOVAL

- Remove the spark plug cap.
- Remove the primary ignition coil wire.
- Remove the ignition coil positioning bolt, and remove the ignition coil.

IGNITION COIL INSTALLATION

Reverse the removal procedure for installation.

When installing, connect the black/yellow wire of the primary ignition coil with the black/yellow connector of CDI, and the green wire the green connector of the CDI.

PRIMARY IGNITION COIL INSPECTION

Standard value	0.1 ~ 1.0K Ω (20°C)
----------------	----------------------------

If the resistance value is ∞ , it indicates the coil is bad and should be replaced.

SECONDARY IGNITION COIL INSPECTION

Install the spark plug cap, and measure the resistance value of the secondary ignition coil.

Standard value	7 ~ 9K Ω (20°C)
----------------	------------------------

The resistance value is in the standard range indicates it is good; however, ∞ indicates the coil is bad.

Remove the spark plug cap, and measure the resistance value of the secondary ignition coil .

Standard value	2 ~ 4K Ω (20°C)
----------------	------------------------

The resistance value is in the standard range indicates it is good; however, ∞ indicates the coil is bad.

THE IGNITION COIL ALSO CAN BE INSPECTED AND MEASURED WITH THE IGNITION-TESTING INSTRUMENT.

Please operate properly according to the instruction.

Set the measuring switch of the ignition coil on the 1.2V position, and connect the ignition coil. Turn the switch of the testing instrument to ON position. Observe the spark over window and inspect the spark over situation of the ignition coil. If it is a normal consistent spark, it is good. If the spark does not flash consistently, it is not good.

SPARK PLUG INSPECTION

Clean the carbon around the spark plug to prevent it from dropping into the cylinder.

Remove the spark plug. (See Section 2-2, SPARK PLUG)



200 Series Light Utility Vehicle
Wiring Diagram

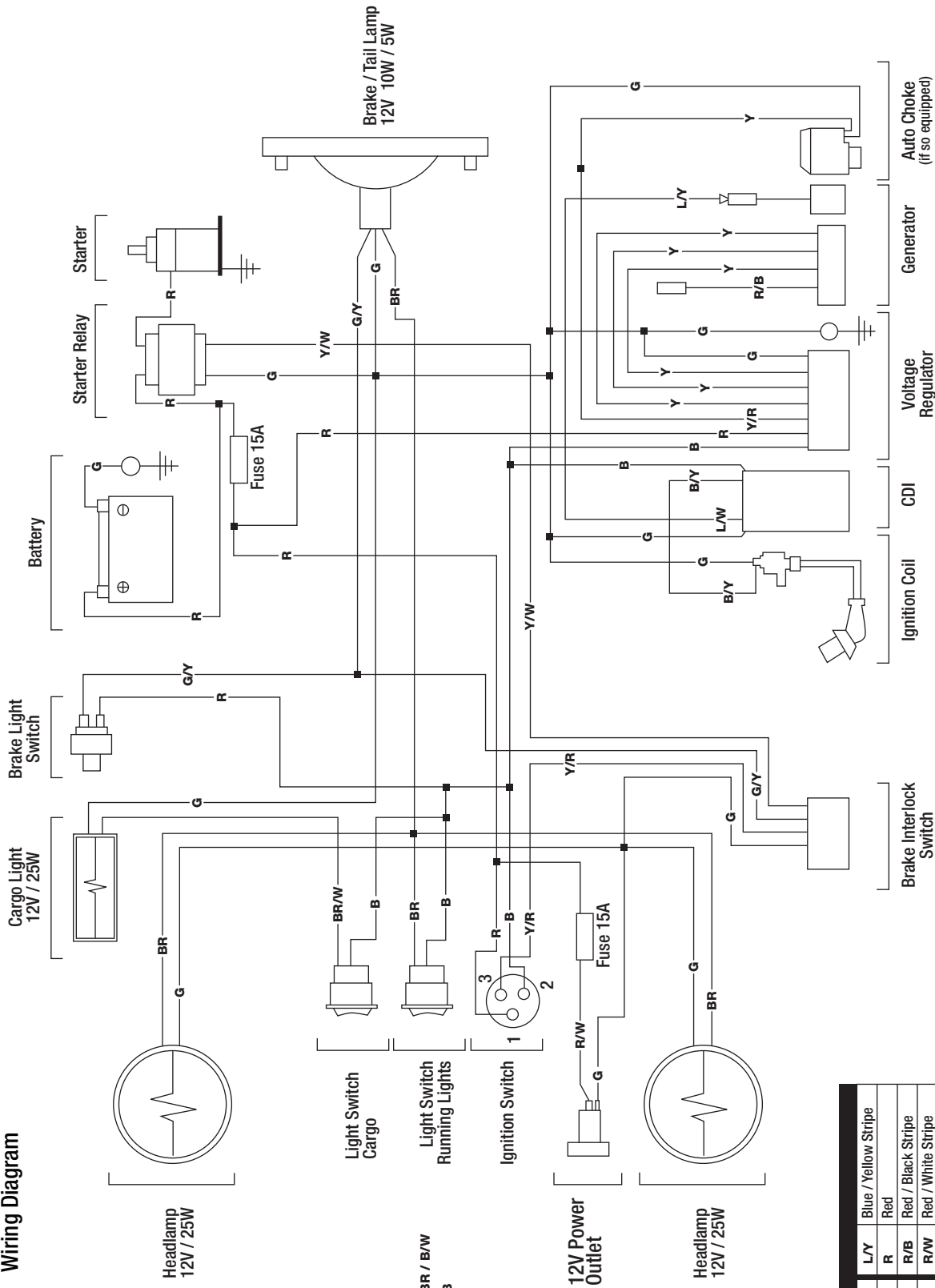

Wire Color Chart	
B	Black
B/W	Black / White Stripe
B/Y	Black / Yellow Stripe
BR	Brown
BR/W	Brown / White Stripe
G	Green
G/Y	Green / Yellow Stripe
L/W	Blue / White Stripe
L/Y	Blue / Yellow Stripe
R	Red
R/B	Red / Black Stripe
R/W	Red / White Stripe
Y	Yellow
Y/R	Yellow / Red Stripe
Y/W	Yellow / White Stripe



150cc Fun Kart Wiring Diagram

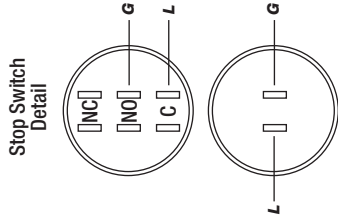
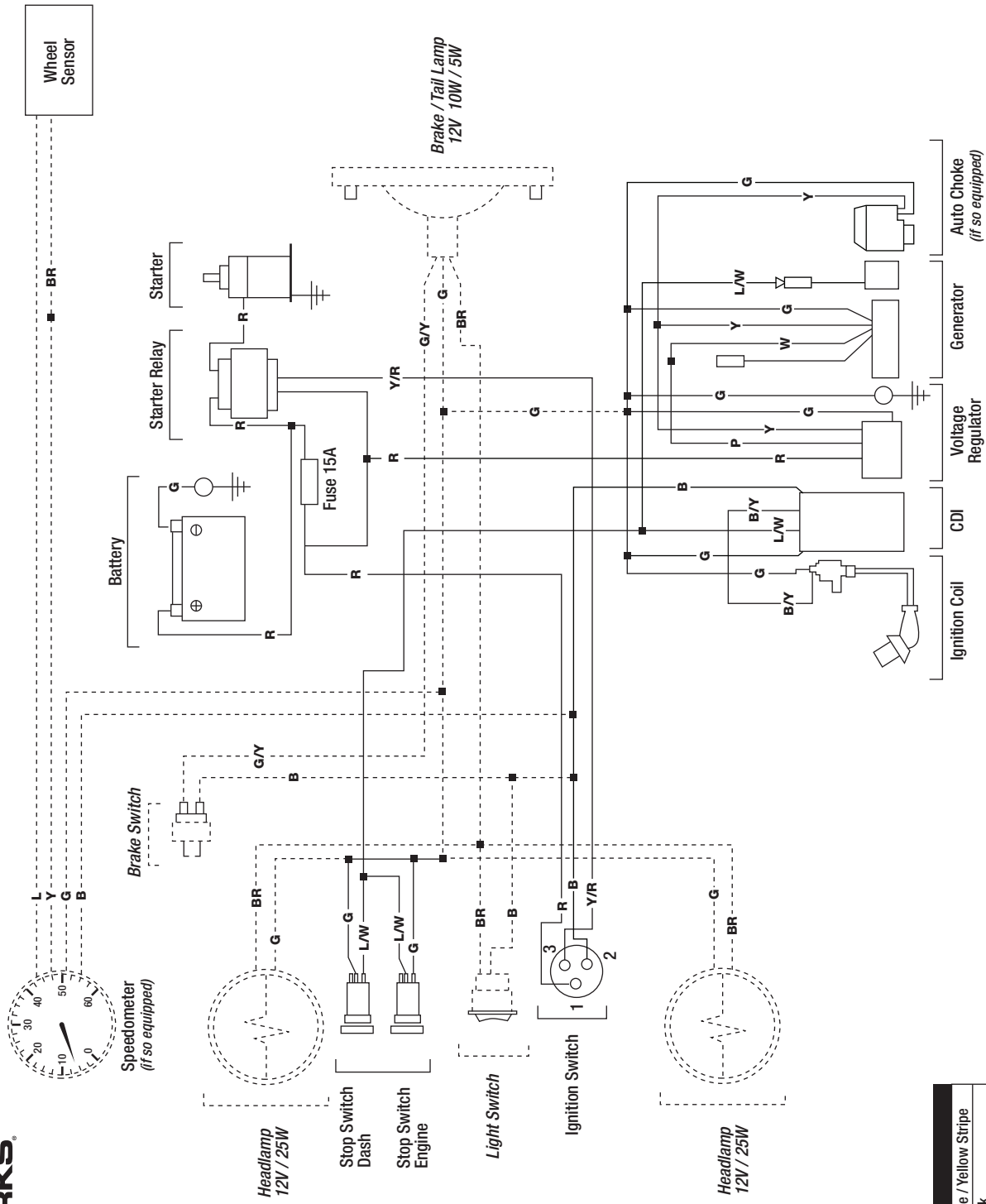

Wire Color Chart	
B	Black
B/W	Black / White Stripe
B/Y	Black / Yellow Stripe
BR	Brown
BR/W	Brown / White Stripe
G	Green
G/Y	Green / Yellow Stripe
L/W	Blue / White Stripe
L/Y	Blue / Yellow Stripe
P	Pink
R	Red
R/B	Red / Black Stripe
R/W	Red / White Stripe
Y	Yellow
Y/R	Yellow / Red Stripe
Y/W	Yellow / White Stripe

5 CHASSIS

CONTENTS

5-1	CHASSIS	76
	CHASSIS SYSTEM INSPECTION AND SERVICING	76
	REAR AXLE REMOVAL	76
	REAR SWINGARM INSPECTION	76
5-2	CHASSIS	77
	FRONT & REAR SHOCKS INSPECTION	77
	FRONT & REAR SHOCK ADJUSTMENT	77
	FRONT WHEEL REPLACEMENT	77
	FRONT HUB INSPECTION	77
5-3	CHASSIS	78
	A-ARM INSPECTION	78
	STEERING KNUCKLE SUPPORT INSPECTION	78
	TIE ROD INSPECTION	78
	FRONT AND REAR SHOCK ADJUSTMENT	78
5-4	CHASSIS	79
	FRONT WHEEL ALIGNMENT	79
	CHAIN ADJUSTMENT	79

5-1 CHASSIS

CHASSIS SYSTEM INSPECTION AND SERVICING

REAR AXLE REMOVAL

- Disassemble the right rear (RR). Wheel
- Remove the Cotter Pins on Axle Nut, RR. Wheel
- Remove the Axle Nut, RR. Wheel
- Block up rear end of the machine
- Remove rear wheel and hub assembly by sliding off the splines of axle
- Remove the chain
- Loosen nuts on bearing carrier and remove bolts
- Remove axle and bearing carriers as a unit

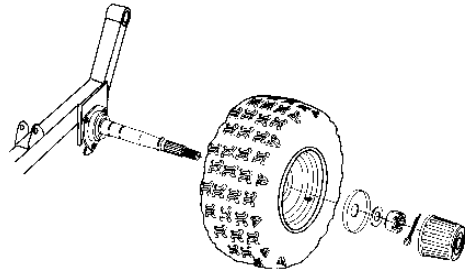

REAR SWINGARM INSPECTION

Note:

Swingarm, axle and motor can be removed as a unit if desired.

Remove Rear. Shocks

Remove rear brake calipers and set aside.

Do not remove brake hose!

Unplug brake light wiring from the electrical box

Remove throttle cable

Remove bolts from swingarm pivot

Check Buffer Rubber Bushing for wear. If wear is present on bushing, it should be replaced.

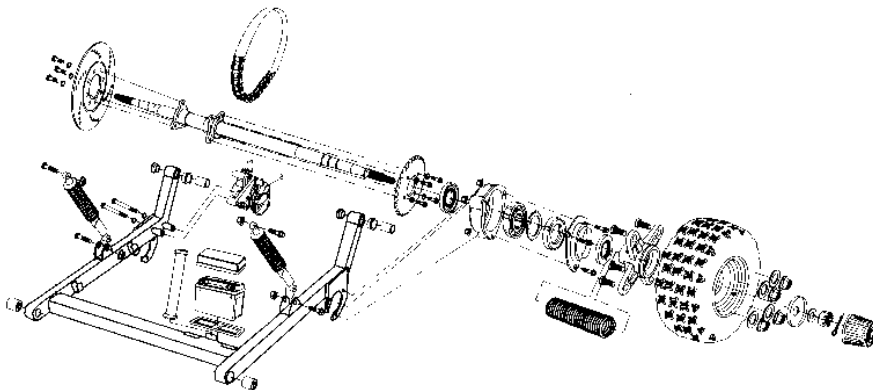
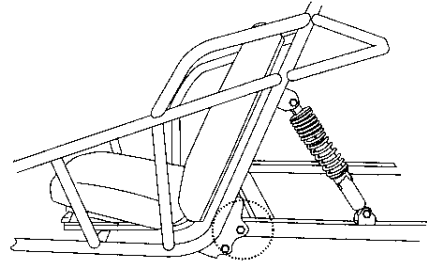

5-2 CHASSIS

FRONT & REAR SHOCKS INSPECTION

The Front and Rear Shocks are oil-dampened units.

They are non rebuildable.

If any oil is noticed, the shock should be replaced.

FRONT & REAR SHOCK ADJUSTMENT

There are 5 positions of choice on each shock, the default position is set by the manufacture in the middle (the third position).

Please use a round nut wrench to adjust the position. The tension of shock spring would increase as you left screw and decrease as you right screw.

FRONT WHEEL REPLACEMENT

Do not disassemble the castle nuts when you replace the front wheels.

It is only necessary to tighten the nuts so that the wheel turns freely on the axle with minimum endplay. Please tighten the nuts after replacing the wheels.

FRONT HUB INSPECTION

Check seals for rips or tears and replace if any exist.

Remove bearings with a punch from the opposite side.

Inspect bearings for ease of movement. If dirt or mud has gotten to them, wash them in cleaning solvent and spin with your finger. Never spin them with compressed air.

Apply an ample amount of grease to the bearing and reinstall with a bearing tool, making sure it goes in straight. If the bearing is not straight, damage to the hub can occur.

Install seals into hub. It is recommended to apply a small amount of grease to the lip of the seal. If the retention spring is in bad shape, replace the seal with a new one.

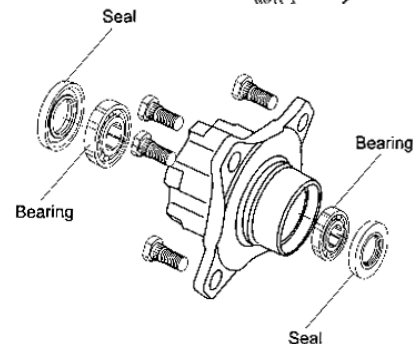
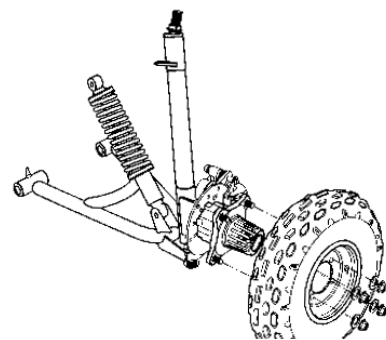
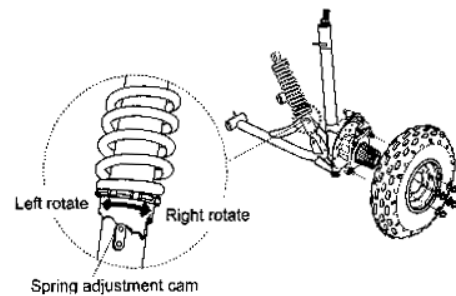
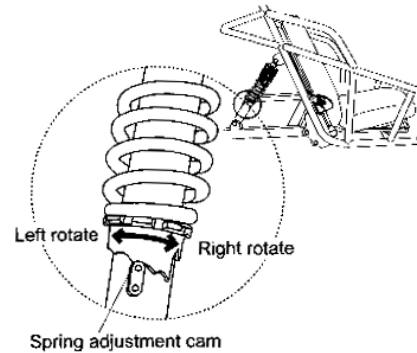

5-3 CHASSIS

A-ARM INSPECTION

Grease the nipples of Upper & Lower A-Arm, for the front wheels periodically

Remove Bolt of Upper & Lower A-Arm.

Check the Nylon Bushing of Upper & Lower A-Arm for wear. Replace them immediately if wear is present.

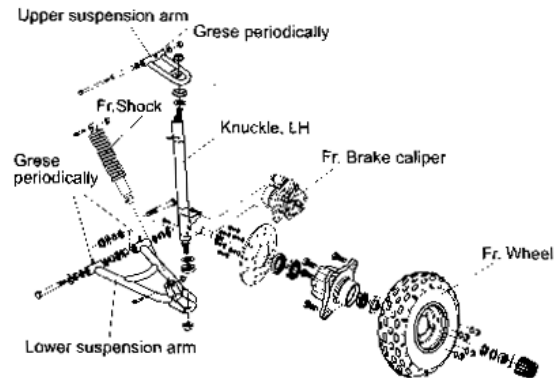

STEERING KNUCKLE SUPPORT INSPECTION

Remove Rubber Dust Cover of the knuckle Support

Check the grease of Ball Joint, clean it if it is dirty, and fill with grease

Replace the Steering Knuckle support if the Ball Joint is loose or steering isn't flexible

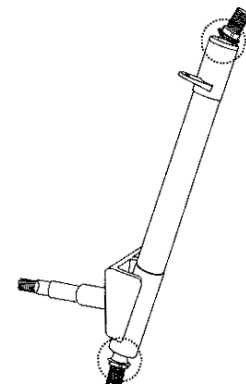

TIE ROD INSPECTION

Tie rods should be checked for ease of movement in their full rotation.

Remove protective boot and apply grease.

Check tie rod ends periodically for tightness at their adjusting nuts.

Always use a new cotter pin after removal.

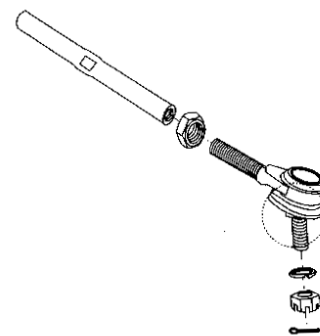

FRONT AND REAR SHOCK ADJUSTMENT

There are five adjustable positions on each shock.

The center notch is the default position as set by the manufacturer (Ref Figure). Use a round nut wrench to adjust the shock.

To INCREASE the shock stiffness, rotate the ring to the highest (longest) setting.

To DECREASE the shock stiffness, rotate the ring to the lowest (shortest) setting.

Shock stiffness adjustments should be made based on the overall weight of the rider and occupant.

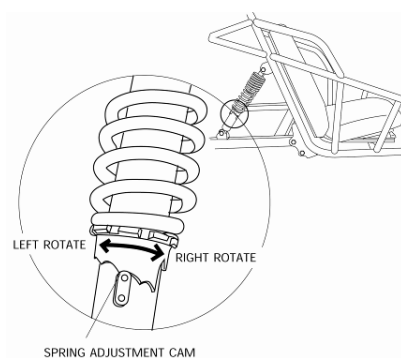

5-4 CHASSIS

FRONT WHEEL ALIGNMENT

The front wheel should be “toed-in” 1/8” to 1/4”.

To check alignment measure distance from A to B to the centerline (CL) of the tires with the wheels point straight ahead. For the proper toe-in dimension A should be 1/8 ~1/4" greater than dimension B.

Loosen the locknuts on both sides of Front Tie Rods. To Make Dimension B smaller, screw the rod left. If B needs to be longer screw the rod right.

Tighten the jam nut tightly against the rod end.

Recheck the distance and repeat the above steps until the Dimensions are per paragraph 1 above.

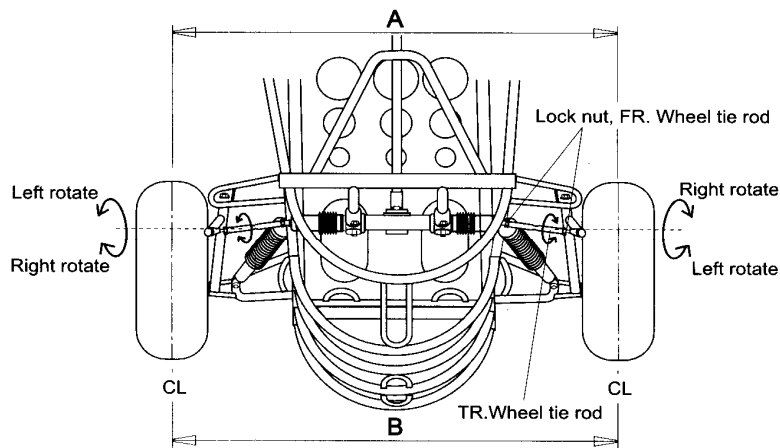

CHAIN ADJUSTMENT

After the first two hours of operation, check the chain adjustment, and readjust if it has more than 1/2" flex.

Loosen Nut 1

Adjust Nut #2 (Turn nut clockwise in 1/2 turn increments, then turn Nut #1 clockwise until nut is tight.)

Follow this procedure until chain is at proper tension.)

